

Temperature Measurement Solutions



Dial Indicating
Electronic
Industrial RTDs
Thermowells
Accessories



At NOSHOK, we pride ourselves on being innovators in the industry by continually offering the latest technology and measurement solutions, and providing the best customer support in the marketplace.

Established in 1967, NOSHOK was one of the first companies to offer liquid filled pressure gauges. We also took a bold step by backing our quality gauges with an extended 3-year warranty. That unwavering standard of quality has endured for over 50 years, and as we have expanded our product offering we continue to provide industry-leading warranties. NOSHOK also leads the industry as one of the first companies to offer corrosion-resistant zinc nickel plating standard on our carbon steel valves.

We have the capacity to put together special requirements which are so often hard to find. If you do not find what you need in this catalog, chances are we can still put a solution together.

NOSHOK is committed to providing excellence on every level. Thank you for choosing NOSHOK products.

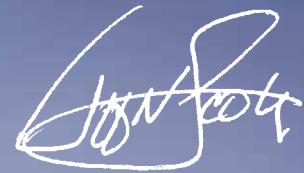

Jeff N. Scott
President



NOSHOK Corporate Headquarters
Your Single Source Instrumentation Company

NOSHOK is a member and actively supports:



NOSHOK is an ISO 9001:2015 registered company.

WARRANTY INFORMATION

NOSHOK's **Eight Year Warranty** applies to our 3" and 5" 300 Series Bimetal Thermometers. Our **Three Year Warranty** applies to our 800 Series Platinum Resistance Temperature Transmitters, 810 Series Compact OEM Temperature Transmitters, 820/821 and 822/823 Series Digital Temperature Indicators, 850 Series Electronic Indicating Temperature Switch/Transmitters, 900/915 Series Probe-Type Industrial RTDs, 910 Series Probe-Type Industrial RTDs with Process Connection and 920 Series RTD Transmitter. Our **One Year Warranty** applies to our 100, 150, 300 (2") and 350 Series Bimetal Thermometers, Vapor Actuated Remote Thermometers and Thermowells.

NOSHOK guarantees all products to be free from defects in material and workmanship, to remain within catalogued accuracy specifications, and to operate within the catalogued performance specifications. These products must be operated within the catalogued environmental and application parameters. Determination of failure will be made by NOSHOK, Inc.'s equipment and personnel or a certified test facility specializing in this type of evaluation.

T A B L E O F C O N T E N T S



DIAL INDICATING THERMOMETERS

Bimetal, Industrial Type:	
100 SERIES	4-7
Bimetal, Testing and General Purpose:	
150 SERIES	8-11
Bimetal, Industrial Type with External Reset:	
300 SERIES	12-15
Bimetal, Testing and General Purpose with External Reset:	
350 SERIES	16-19
Vapor Actuated Remote:	
300/400/600/700/900 SERIES	20-27

DIAL INDICATING THERMOMETER OPTIONS

Maximum Indicating Pointer, Silicone Filled, Stem Types, Connections, Special Dials, Lenses, Certified Calibration	28-29
--	-------

ELECTRONIC TEMPERATURE MEASUREMENT

Platinum Resistance Temperature Transmitter:	
800 SERIES	30-31
Compact OEM Temperature Transmitter:	
810 SERIES	32-33
Digital Temperature Indicator:	
820/821 SERIES	34-35
Digital Temperature Indicator, Battery Powered	
822/823 SERIES	36-37
Electronic Indicating Temperature Transmitter/Switch:	
850 SERIES	38-39

INDUSTRIAL RESISTANCE TEMPERATURE DEVICES (RTD)

Industrial RTD, Probe Type:	
900 SERIES	40-41
Industrial RTD, Probe Type with Connection Head:	
910/915 SERIES	42-43
RTD Transmitter:	
920 SERIES	44

RTD ACCESSORIES

Connection Heads, Terminal Blocks	45
---	----

THERMOWELLS

Thermowells:	
50/75/100 SERIES	46-48
Reference Information	49-53

In keeping with and for purpose of product and/or manufacturing process improvements, NOSHOK, Inc. reserves the right to make design changes without prior notice.

Bimetal, Industrial Type

100 SERIES



- Heavy-duty, industrial thermometer featuring a weather-resistant, tamper-proof case
- Single °F, single °C, and dual scale options available
- Accuracy: ±1% full scale, Grade A, ASME B40.3
- 1-3/4", 2", 3" and 5" sizes - center back connection only
- 304 Stainless Steel case and bezel
- Standard stem lengths 2-1/2" through 42"
- Highly sensitive bimetallic helix coil is heat-treated for stress relief, and silicone-coated to minimize pointer vibration and maximize heat transfer and response time
- 360° groove around stem is a visual reference to show minimum immersion point
- Made in the U.S.A.

APPLICATIONS

Used in almost every area of manufacturing, especially suited for applications in the following areas:

- Industrial process
- Petrochemical
- Food & beverage processing
- Commercial
- Wastewater

	SERIES	SPECIFICATIONS
Case & bezel	All 100 Series	304 Stainless Steel; 316 Stainless Steel optional
Lens	All 100 Series	Instrument glass
Pointer	All 100 Series	Aluminum, black finish
Stem diameter	18-110 20-110, 30-110, 50-110	.150" (3.81 mm) .250" (6.35 mm)
Accuracy	All 100 Series	±1% full scale, Grade A, ASME B40.3
Dial	All 100 Series	Anodized Aluminum with large black numbers and graduations
Process connection	18-110 20-110 30-110, 50-110	1/4" NPT, 1/8" and 3/8" NPT optional 1/4" NPT 1/2" NPT
Wetted parts	All 100 Series	304 Stainless Steel; 316 Stainless Steel optional
Hermetic seal	All 100 Series	Per ASME B40.3 dustproof and leakproof
Bimetal coil	All 100 Series	Silicone coated helix coil on ranges below 500 °F for vibration dampening, maximum heat transfer and response time
Over temperature limits	All 100 Series	Up to 250 °F 100%; 250 °F to 550 °F 50%; 550 °F to 1,000 °F continuous use up to 800 °F; intermittent use over 800 °F



WARNING: This product can expose you to chemicals including Chromium (VI) and Nickel, which are known to the State of California to cause cancer and birth defects or other reproductive harm. For more information go to www.P65Warnings.ca.gov

Thermowells are recommended for pressure, corrosive fluids and high velocity applications, see pages 46-48.

ORDERING INFORMATION					
DIAL SIZES	18	1-3/4" ††	30	3"	
	20	2"	50	5"	
CASE TYPES	110	Back connection			
STEM LENGTHS	025	2-1/2"	090	9"	240 24"
Available up to 120"	040	4"	120	12"	300 30"
	060	6"	150	15"	360 36"
	080	8" †	180	18"	420 42"
TEMPERATURE RANGES	-100/100 F/C	-100 °F/°C to 100 °F/°C	0/250 F/C	0 °F/°C to 250 °F/°C	50/500 F/C 50 °F/°C to 500 °F/°C
<i>Dual Scale °F/°C</i>	-40/160 F/C	-40 °F/°C to 160 °F/°C	20/240 F/C	20 °F/°C to 240 °F/°C	150/750 F/C 150 °F/°C to 750 °F/°C
	0/140 F/C	0 °F/°C to 140 °F/°C	25/125 F/C	25 °F/°C to 125 °F/°C	200/1000 F/C 200 °F/°C to 1,000 °F/°C*
	0/180 F/C	0 °F/°C to 180 °F/°C	50/300 F/C	50 °F/°C to 300 °F/°C	
	0/220 F/C	0 °F/°C to 220 °F/°C	50/400 F/C	50 °F/°C to 400 °F/°C	
<i>Single Scale °F</i>	-100/100 F	-100 °F to 100 °F	0/300 F	0 °F to 300 °F**	50/550 F 50 °F to 550 °F
	-50/120 F	-50 °F to 120 °F	0/500 F	0 °F to 500 °F**	100/800 F 100 °F to 800 °F**
	-40/160 F	-40 °F to 160 °F	20/240 F	20 °F to 240 °F	150/750 F 150 °F to 750 °F
	0/140 F	0 °F to 140 °F	25/125 F	25 °F to 125 °F	200/1000 F 200 °F to 1,000 °F*
	0/180 F	0 °F to 180 °F	50/250 F	50 °F to 250 °F	
	0/200 F	0 °F to 200 °F	50/300 F	50 °F to 300 °F	
	0/220 F	0 °F to 220 °F	50/400 F	50 °F to 400 °F	
	0/250 F	0 °F to 250 °F	50/500 F	50 °F to 500 °F	
<i>Single Scale °C</i>	-75/175 C	-75 °C to 175 °C	0/50 C	0 °C to 50 °C	0/300 C 0 °C to 300 °C
	-70/70 C	-70 °C to 70 °C**	0/60 C	0 °C to 60 °C**	0/400 C 0 °C to 400 °C
	-50/100 C	-50 °C to 100 °C**	0/80 C	0 °C to 80 °C**	0/450 C 0 °C to 450 °C
	-50/50 C	-50 °C to 50 °C	0/100 C	0 °C to 100 °C	100/400 C 100 °C to 400 °C
	-40/70 C	-40 °C to 70 °C	0/150 C	0 °C to 150 °C	100/550 C 100 °C to 550 °C*
	-20/120 C	-20 °C to 120 °C**	0/200 C	0 °C to 200 °C	
	-10/110 C	-10 °C to 110 °C**	0/250 C	0 °C to 250 °C	
	Consult factory for additional temperature ranges				
OPTIONS	1/8	1/8" NPT †	AU	1/2" NPT Adjustable Union **	SL Silicone Filled ***
	3/8	3/8" NPT †	HD	Heavy-Duty Stem (0.375" Dia.) **	ST Stainless Steel Tagging
	6	6 mm stem diameter **	LL	Polycarbonate Lens	TG Tempered Glass Lens †††
	8	8 mm stem diameter **	PL	Acrylic Lens	
	316	316 SS Wetted Parts **	SG	Safety Glass Lens **	

Please consult your local NOSHOK Distributor or NOSHOK, Inc. for availability and delivery information.

Note: All 316 Stainless Steel construction (case, bezel, wetted parts) is available. Please consult factory.

- * Thermometers with temperature ranges 200/1,000 °F and 100/500 °C are not recommended for continuous use above 800 °F/425 °C. For intermittent use only.
- ** Available for 30-110 and 50-110 models only.
- *** Available for 20-110, 30-110 and 50-110 models only. Available only for ranges from -50 °F (-45 °C) to 500 °F (260 °C). Polycarbonate lens is standard with Silicone Fill.
- † Available for 18-110 model only.
- †† 18-110 model is only available in 2-1/2", 4", 6", 8", 12", 15" and 18" stem lengths.
- ††† Not available with Silicone Filled (SL) option.

EXAMPLE

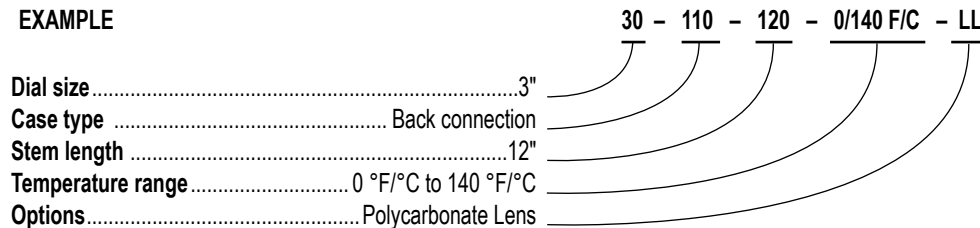

Dimensions

18-110

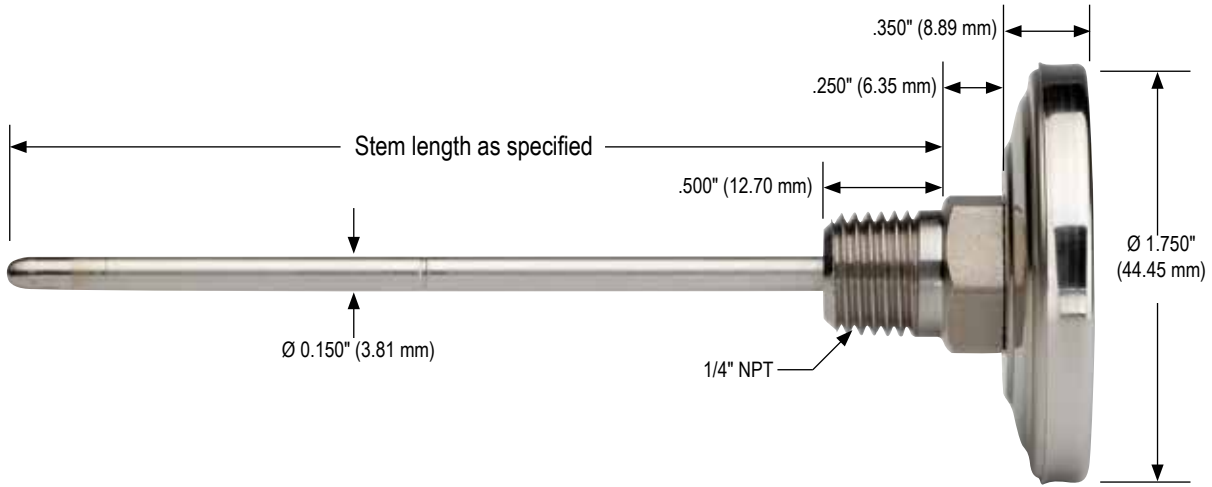

20-110

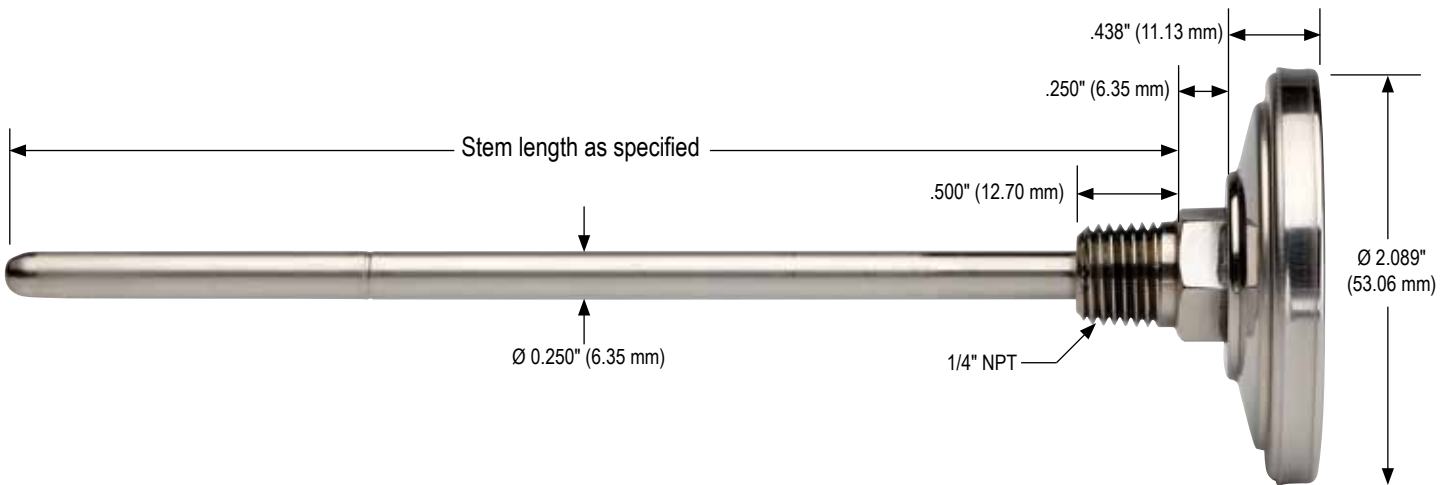

30-110

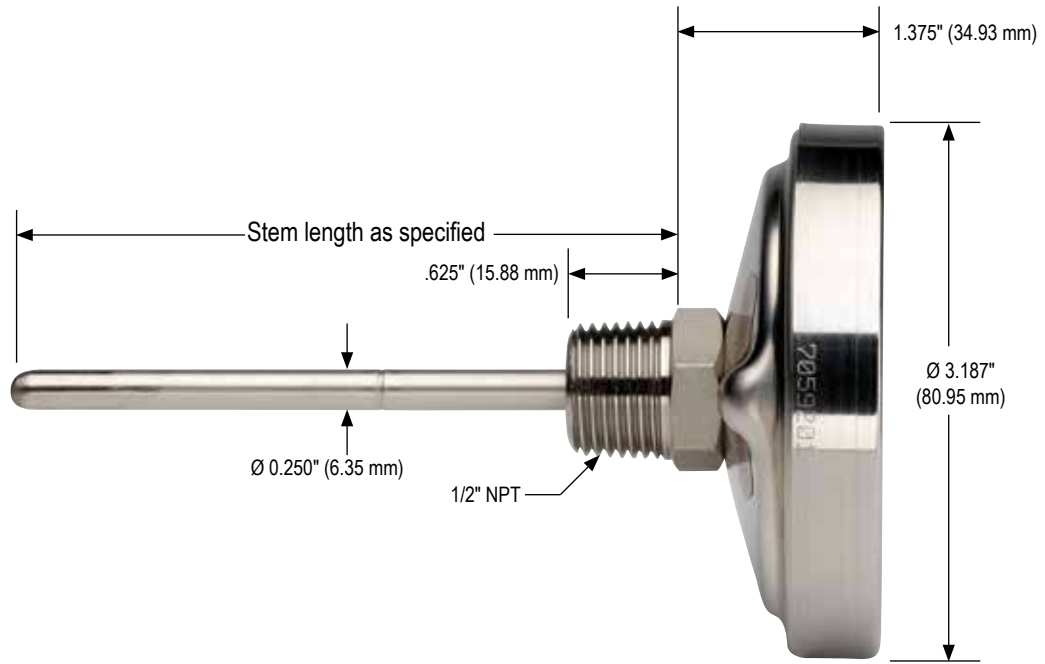

50-110

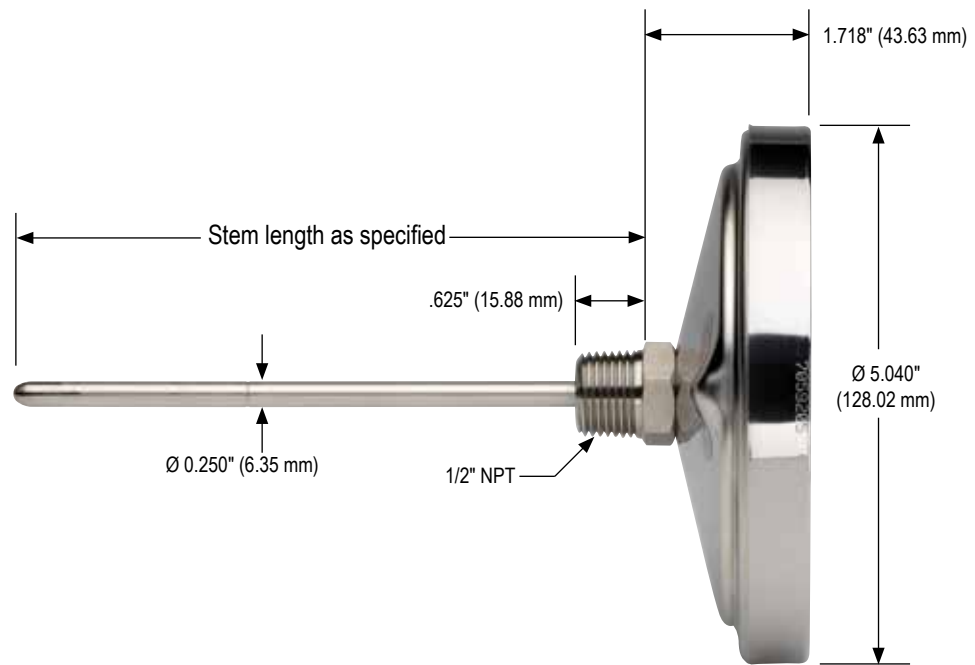

Bimetal, Testing and General Purpose

150 SERIES



- Designed for general purpose testing applications, featuring a weather-resistant, tamper-proof case
- Pocket sized model is used by inspectors, service and maintenance personnel for spot checking
- Single °F, single °C, and dual scale options (1-3/4" and 2" models only) available
- Accuracy: ±1% full scale, Grade A, ASME B40.3
- 1", 1-3/4" and 2" sizes - center back connection only
- 304 Stainless Steel case and bezel
- Highly sensitive bimetallic helix coil is heat-treated for stress relief, and silicone-coated to minimize pointer vibration and maximize heat transfer and response time
- 360° groove around stem is a visual reference to show minimum immersion point
- Made in the U.S.A.

APPLICATIONS

Used in almost every area of manufacturing, especially suited for laboratory testing and general purpose applications in the following areas:

- Laboratory
- Food & beverage processing
- Concrete
- Asphalt
- OEM equipment

	SERIES	SPECIFICATIONS
Case & bezel	All 150 Series	304 Stainless Steel
Lens	All 150 Series	Instrument glass
Pointer	All 150 Series	Aluminum, black finish
Stem diameter	All 150 Series	.150" (3.81 mm)
Accuracy	All 150 Series	±1% full scale, Grade A, ASME B40.3
Dial	All 150 Series	Anodized Aluminum with large black numbers and graduations
Wetted parts	All 150 Series	304 Stainless Steel
Hermetic seal	All 150 Series	Per ASME B40.3 dustproof and leakproof
Bimetal coil	All 150 Series	Silicone coated helix coil on ranges below 500 °F for vibration dampening, maximum heat transfer and response time
Over temperature limits	All 150 Series	Up to 250 °F 100%; 250 °F to 550 °F 50%; 550 °F to 1,000 °F continuous use up to 800 °F; intermittent use over 800 °F



WARNING: This product can expose you to chemicals including Chromium (VI) and Nickel, which are known to the State of California to cause cancer and birth defects or other reproductive harm. For more information go to www.P65Warnings.ca.gov

Thermowells are recommended for pressure, corrosive fluids and high velocity applications, see pages 46-48.

ORDERING INFORMATION						
DIAL SIZES	10	1" **	18	1-3/4"	20	2"
CASE TYPES	150	Back connection				
STEM LENGTHS	050	5"	120	12" †		
	080	8"	180	18" †		
TEMPERATURE RANGES	-100/100 F/C	-100 °F/°C to 100 °F/°C	0/250 F/C	0 °F/°C to 250 °F/°C	50/550 F/C	50 °F/°C to 550 °F/°C
	-40/160 F/C	-40 °F/°C to 160 °F/°C	20/240 F/C	20 °F/°C to 240 °F/°C	150/750 F/C	150 °F/°C to 750 °F/°C
<i>Dual Scale °F/°C</i>	0/140 F/C	0 °F/°C to 140 °F/°C	25/125 F/C	25 °F/°C to 125 °F/°C	200/1000 F/C	200 °F/°C to 1,000 °F/°C *
(Not available on 1" model)	0/180 F/C	0 °F/°C to 180 °F/°C	50/300 F/C	50 °F/°C to 300 °F/°C		
	0/220 F/C	0 °F/°C to 220 °F/°C	50/400 F/C	50 °F/°C to 400 °F/°C		
<i>Single Scale °F</i>	-100/100 F	-100 °F to 100 °F	0/220 F	0 °F to 220 °F **	50/400 F	50 °F to 400 °F
	-50/120 F	-50 °F to 120 °F	0/250 F	0 °F to 250 °F	50/500 F	50 °F to 500 °F **
	-40/160 F	-40 °F to 160 °F **	20/240 F	20 °F to 240 °F	50/550 F	50 °F to 550 °F
	0/140 F	0 °F to 140 °F	25/125 F	25 °F to 125 °F **	150/750 F	150 °F to 750 °F **
	0/180 F	0 °F to 180 °F	50/250 F	50 °F to 250 °F	200/1000 F	200 °F to 1,000 °F *
	0/200 F	0 °F to 200 °F	50/300 F	50 °F to 300 °F		
<i>Single Scale °C</i>	-75/175 C	-75 °C to 175 °C	-10/110 C	-10 °C to 110 °C **	0/300 C	0 °C to 300 °C
	-50/100 C	-50 °C to 100 °C	0/50 C	0 °C to 50 °C **	0/400 C	0 °C to 400 °C
	-50/25 C	-50 °C to 25 °C	0/100 C	0 °C to 100 °C	100/400 C	100 °C to 400 °C
	-50/50 C	-50 °C to 50 °C	0/150 C	0 °C to 150 °C	100/550 C	100 °C to 550 °C *
	-40/70 C	-40 °C to 70 °C **	0/200 C	0 °C to 200 °C		
	-20/120 C	-20 °C to 120 °C	0/250 C	0 °C to 250 °C **		
	Consult factory for additional temperature ranges					
OPTIONS	LL	Polycarbonate Lens	PS	Pocket Sheath ***	ST	Stainless Steel Tagging
	PL	Acrylic Lens †	SL	Silicone Filled †	TG	Tempered Glass Lens † †

Please consult your local NOSHOK Distributor or NOSHOK, Inc. for availability and delivery information.

- * Thermometers with temperature ranges 200/1000 °F and 100/500 °C are not recommended for continuous use above 800 °F/425 °C. For intermittent use only.
- ** 1" model available only in these ranges.
- *** Available for 10-150 and 18-150 models only, with stem lengths of 5" or 8".
- † Available for 20-150 models only. Available only for ranges from -50 °F (-45 °C) to 500 °F (260 °C). Polycarbonate lens is standard with Silicone Fill.
- † † Not available on 10-150 model. Also not available with Silicone Filled (SL) option.

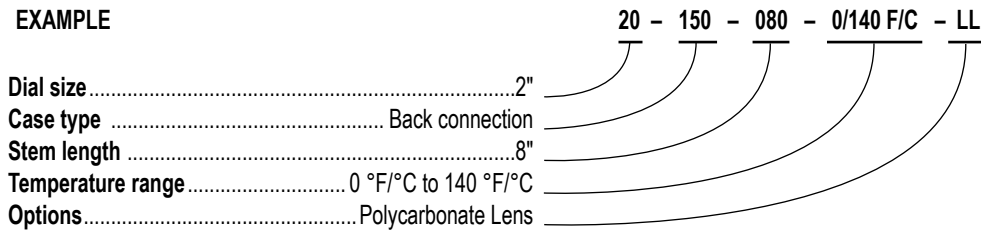

Dimensions

10-150

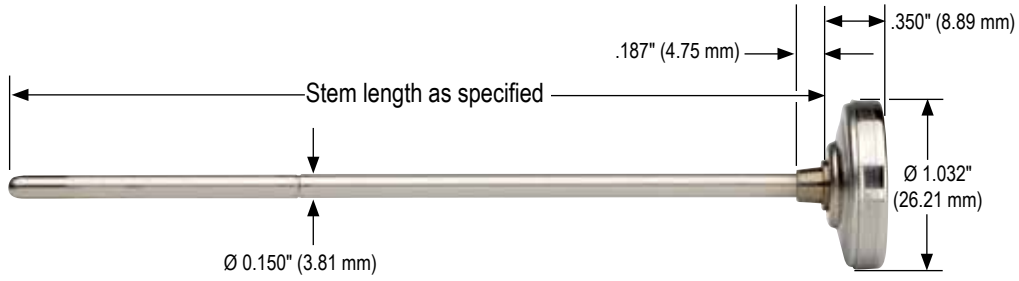

18-150

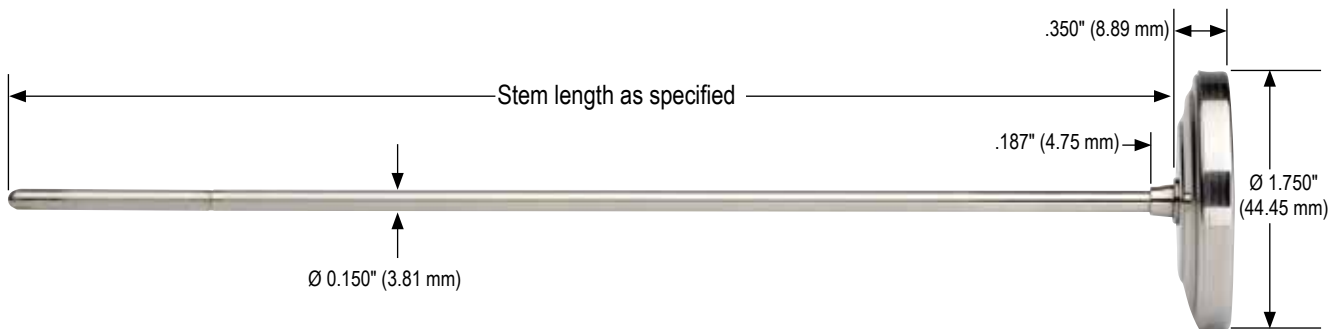

20-150

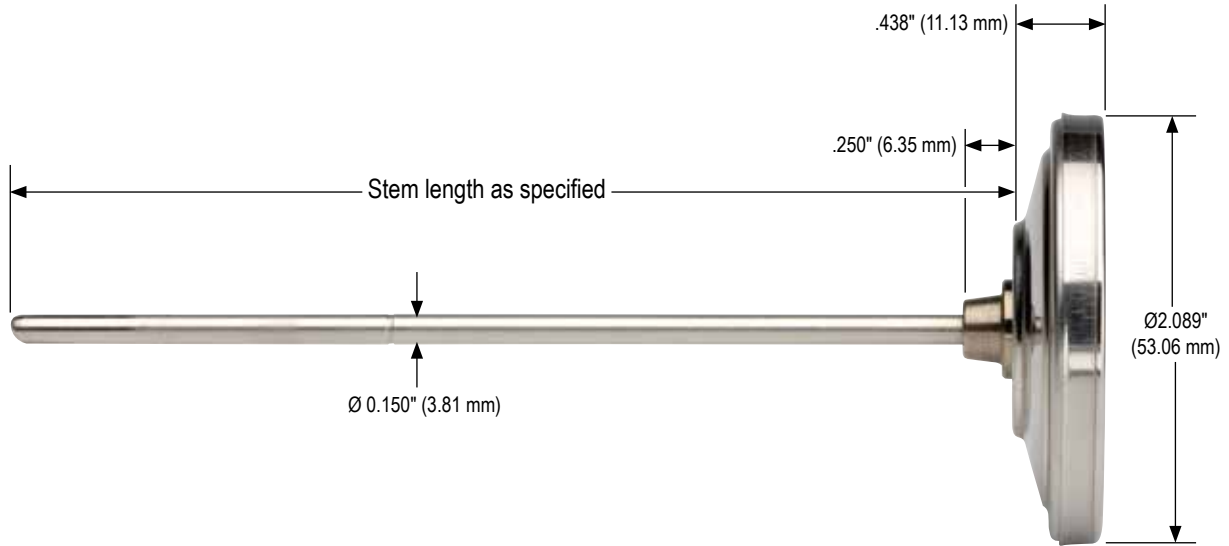

Bimetal, Industrial Type with External Reset

300 SERIES



APPLICATIONS

- Industrial process
- Petrochemical
- Food & beverage processing
- Commercial
- Wastewater

- Highest quality thermometers available on the market
- Easy to calibrate with 1/16" Allen key
- Corrosion-resistant 304 Stainless Steel case and bezel provide a hermetic seal to prevent lens fogging and moisture damage
- Single °F, single °C, and dual scale options available
- Accuracy: $\pm 1\%$ full scale, Grade A, ASME B40.3
- 2", 3" and 5" sizes - center back and bottom connections
- 2" Dial Size - 1/4" NPT; 3" & 5" Dial Sizes - 1/2" NPT
- Standard stem lengths 2-1/2" through 42"
- Minimum or maximum indicating pointers are available in 3" and 5" sizes
- Highly sensitive bimetallic helix coil is heat-treated for stress relief, and silicone-coated to minimize pointer vibration and maximize heat transfer and response time
- 360° groove around stem is a visual reference to show minimum immersion point
- Made in the U.S.A.

	SERIES	SPECIFICATIONS
Case & bezel	All 300 Series	304 Stainless Steel; 316 Stainless Steel optional
Lens	All 300 Series	Instrument glass
Pointer	All 300 Series	Aluminum, black finish
Stem diameter	All 300 Series	.250" (6.35 mm)
Accuracy	All 300 Series	$\pm 1\%$ full scale, Grade A, ASME B40.3
Dial	All 300 Series	Anodized Aluminum with large black numbers and graduations
Process connection	2" Dial Size 3" & 5" Dial Size	1/4" NPT 1/2" NPT
Wetted parts	All 300 Series	304 Stainless Steel; 316 Stainless Steel optional
Hermetic seal	All 300 Series	Per ASME B40.3 dustproof and leakproof
Bimetal coil	All 300 Series	Silicone coated helix coil on ranges below 500 °F for vibration dampening, maximum heat transfer and response time
Over temperature limits	All 300 Series	Up to 250 °F 100%; 250 °F to 550 °F 50%; 550 °F to 1,000 °F continuous use up to 800 °F; intermittent use over 800 °F
Recalibrator	All 300 Series	External reset
Adjustable angle form	320 Series	All Stainless Steel brackets with screws that loosen to allow 360° rotation of head and 180° adjustment of stem position



WARNING: This product can expose you to chemicals including Chromium (VI) and Nickel, which are known to the State of California to cause cancer and birth defects or other reproductive harm. For more information go to www.P65Warnings.ca.gov

Thermowells are recommended for pressure, corrosive fluids and high velocity applications, see pages 46-48.

ORDERING INFORMATION						
DIAL SIZES	20	2" (Back connected only)	30	3"	50	5"
CASE TYPES	300	Bottom connection	310	Back connection	320	Adjustable angle connection **
STEM LENGTHS	025	2-1/2"	120	12"	300	30"
	040	4"	150	15"	360	36"
	060	6"	180	18"	420	42"
	090	9"	240	24"	Available up to 120"	
TEMPERATURE RANGES	-100/100 F/C	-100 °F/°C to 100 °F/°C	0/250 F/C	0 °F/°C to 250 °F/°C	50/500 F/C	50 °F/°C to 500 °F/°C
	-40/160 F/C	-40 °F/°C to 160 °F/°C	20/240 F/C	20 °F/°C to 240 °F/°C	150/750 F/C	150 °F/°C to 750 °F/°C
Dual Scale °F/°C	0/140 F/C	0 °F/°C to 140 °F/°C	25/125 F/C	25 °F/°C to 125 °F/°C †	200/1000 F/C	200 °F/°C to 1,000 °F/°C *
	0/180 F/C	0 °F/°C to 180 °F/°C	50/300 F/C	50 °F/°C to 300 °F/°C		
	0/220 F/C	0 °F/°C to 220 °F/°C	50/400 F/C	50 °F/°C to 400 °F/°C		
Single Scale °F	-100/100 F	-100 °F to 100 °F	0/300 F	0 °F to 300 °F**	50/550 F	50 °F to 550 °F
	-50/120 F	-50 °F to 120 °F	0/500 F	0 °F to 500 °F**	100/800 F	100 °F to 800 °F**
	-40/160 F	-40 °F to 160 °F	20/240 F	20 °F to 240 °F	150/750 F	150 °F to 750 °F
	0/140 F	0 °F to 140 °F	25/125 F	25 °F to 125 °F	200/1000 F	200 °F to 1,000 °F*
	0/180 F	0 °F to 180 °F	50/250 F	50 °F to 250 °F		
	0/200 F	0 °F to 200 °F	50/300 F	50 °F to 300 °F		
	0/220 F	0 °F to 220 °F	50/400 F	50 °F to 400 °F		
	0/250 F	0 °F to 250 °F	50/500 F	50 °F to 500 °F		
Single Scale °C	-75/175 C	-75 °C to 175 °C	0/50 C	0 °C to 50 °C	0/300 C	0 °C to 300 °C
	-70/70 C	-70 °C to 70 °C **	0/60 C	0 °C to 60 °C **	0/400 C	0 °C to 400 °C
	-50/100 C	-50 °C to 100 °C **	0/80 C	0 °C to 80 °C **	0/450 C	0 °C to 450 °C
	-50/50 C	-50 °C to 50 °C	0/100 C	0 °C to 100 °C	100/400 C	100 °C to 400 °C
	-40/70 C	-40 °C to 70 °C	0/150 C	0 °C to 150 °C	100/550 C	100 °C to 550 °C *
	-20/120 C	-20 °C to 120 °C **	0/200 C	0 °C to 200 °C		
	-10/110 C	-10 °C to 110 °C **	0/250 C	0 °C to 250 °C		
	Consult factory for additional temperature ranges					
OPTIONS	6	6 mm stem diameter **	HD	Heavy-Duty Stem (0.375" Dia.) **	SG	Safety Glass Lens **
	8	8 mm stem diameter **	LL	Polycarbonate Lens	SL	Silicone Filled †††
	316	316 SS Connection & Stem **	MIP	Min or Max Indicating Pointer***	ST	Stainless Steel Tagging
	AU	1/2" NPT Adjustable Union**	MIP2	Min and Max Indicating Pointers***	TG	Tempered Glass Lens ††
	GD	Glow Dial †	PL	Acrylic Lens		

Please consult your local NOSHOK Distributor or NOSHOK, Inc. for availability and delivery information.

Note: All 316 Stainless Steel construction (case, bezel, wetted parts) is available. Please consult factory.

* Thermometers with temperature ranges 200/1000 °F and 100/500 °C are not recommended for continuous use above 800 °F/425 °C. For intermittent use only.

** Available for 3" and 5" dial sizes only.

*** Available only on 30-310 and 50-310 models.

† Available only on 50-310 and 50-320 model. Includes reflective pointer and two reflective clips.

†† Not available with Silicone Filled (SL) option.

††† Available only for ranges from -50 °F (-45 °C) to 500 °F (260 °C). Polycarbonate lens is standard with Silicone Fill.

EXAMPLE

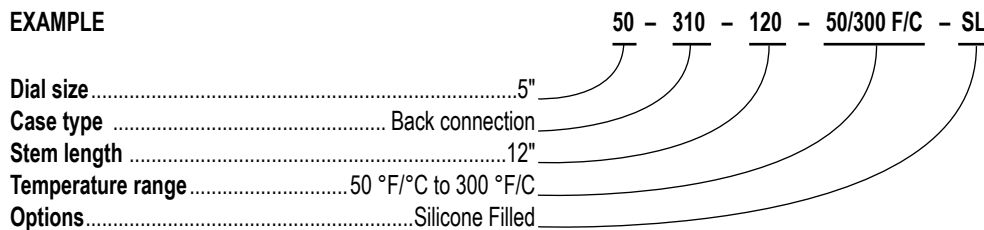

Dimensions

20-310

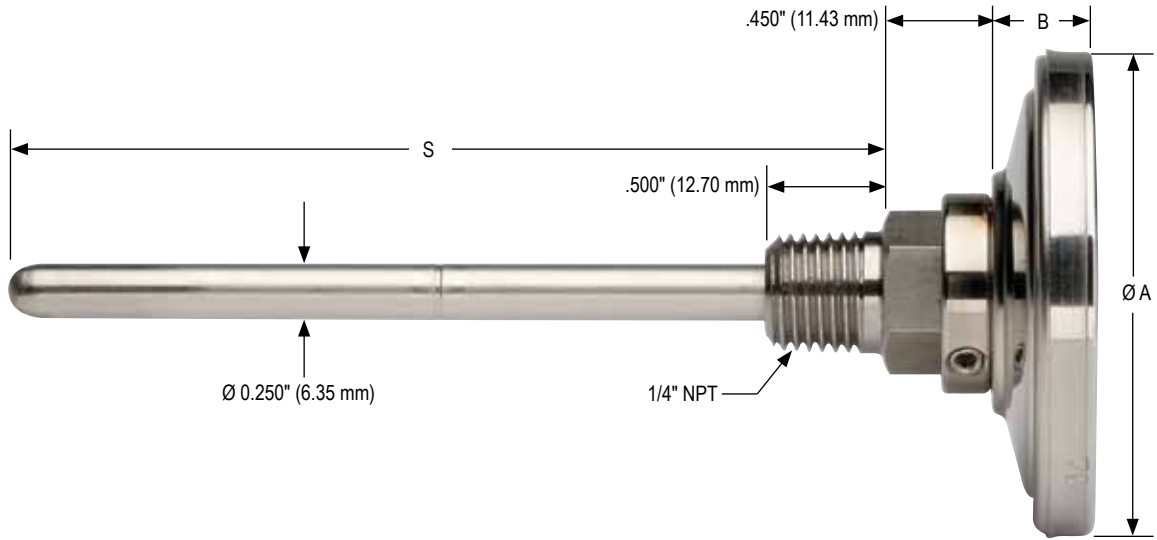

See page 15 for dimension chart.

30-310/50-310

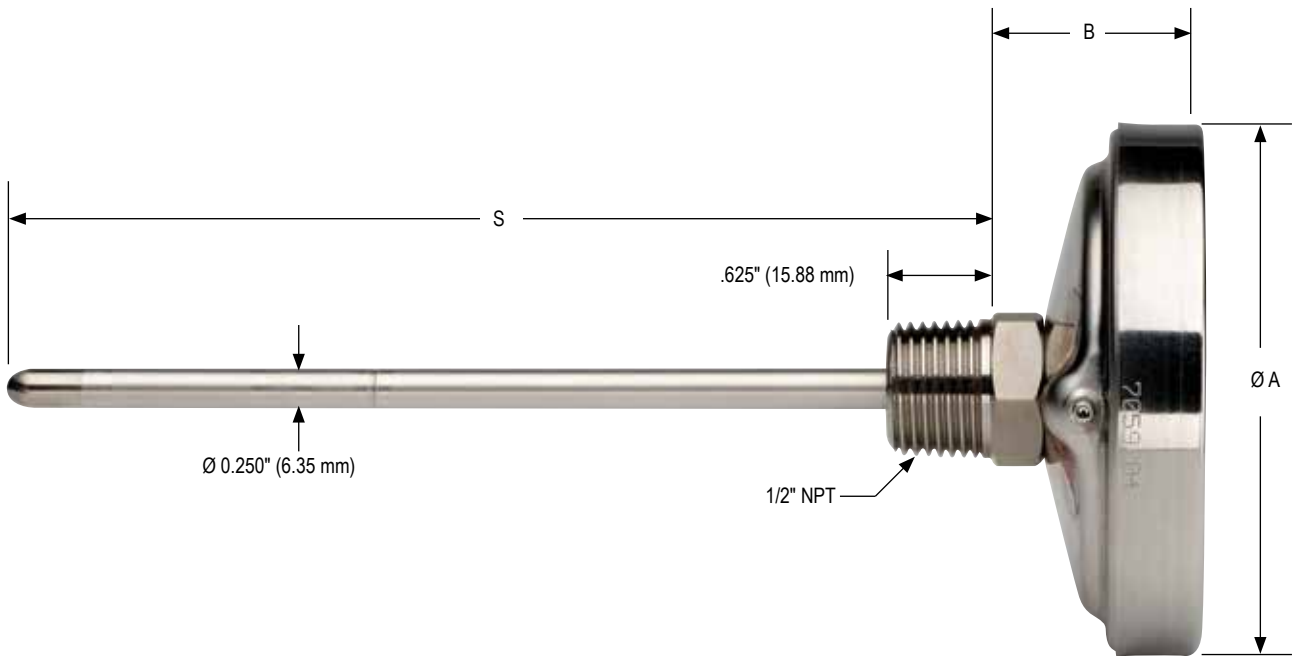

See page 15 for dimension chart.

30-300/50-300

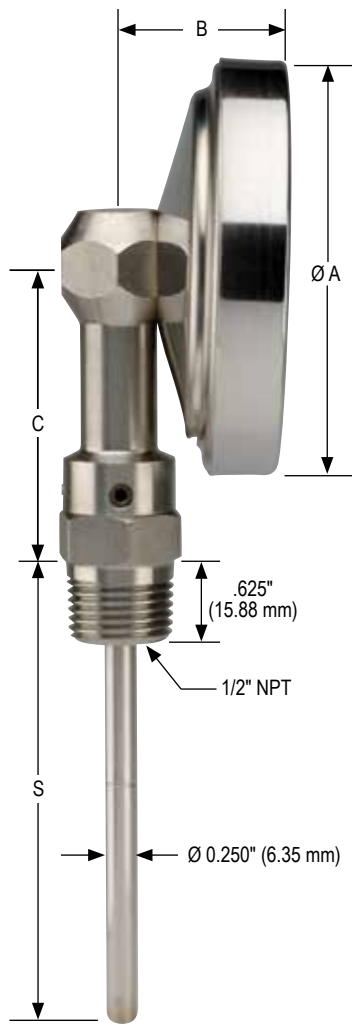

30-320/50-320

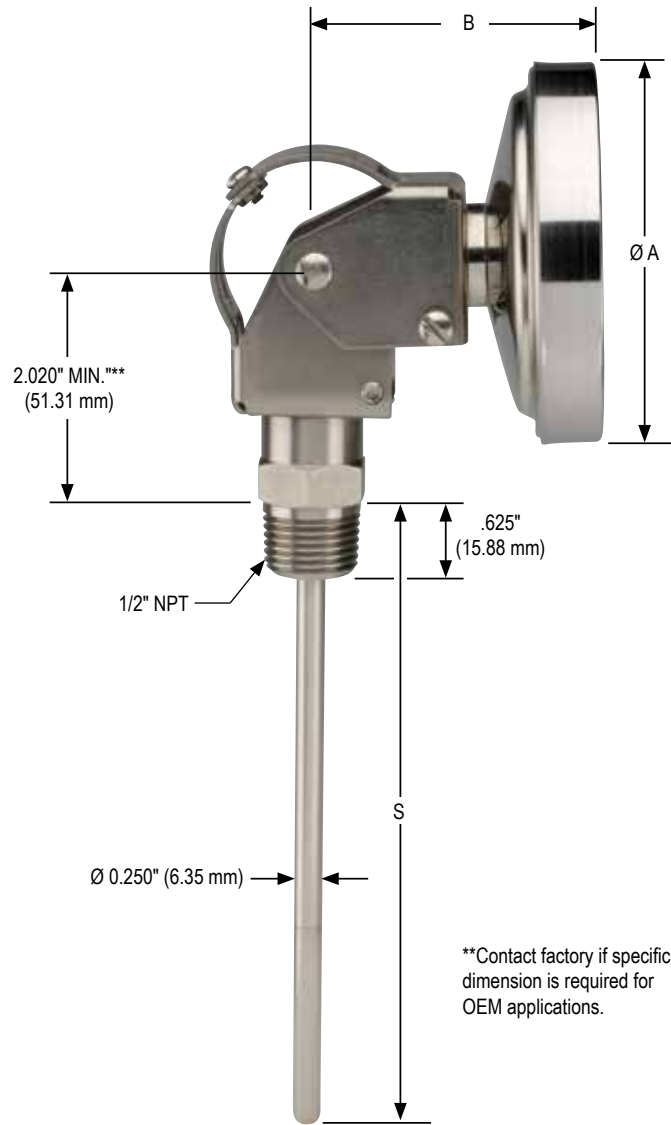

**Contact factory if specific dimension is required for OEM applications.

Series	Ø A	B	C	S (Stem Length)
20-310	2.089" 53.06 mm	.438" 11.13 mm	—	As specified
30-310	3.187" 80.95 mm	1.375" 34.93 mm	—	As specified
50-310	5.040" 128.02 mm	1.718" 43.63 mm	—	As specified
30-300	3.187" 80.95 mm	1.187" 30.15 mm	2.300" (58.42 mm)	As specified
50-300	5.040" 128.02 mm	1.625" 41.28 mm	3.000" (76.20 mm)	As specified
30-320	3.187" 80.95 mm	2.430" 61.72 mm	—	As specified
50-320	5.040" 128.02 mm	2.660" 67.56 mm	—	As specified

Bimetal, Testing and General Purpose with External Reset

350 SERIES



- Designed for general purpose testing applications, featuring a weather-resistant, tamper-proof case
- Pocket sized model is used by inspectors, service and maintenance personnel for spot checking
- A friction adjustment nut design provides easy calibration and maximum accuracy at a selected range
- Single °F, single °C, and dual scale (1-3/4" and 2" models only) options available
- Accuracy: ±1% full scale, Grade A, ASME B40.3
- 1", 1-3/8", 1-3/4", 2" and 3" sizes - center back connection only
- 304 Stainless Steel case and bezel
- Standard stem lengths 5 through 18"
- Highly sensitive bimetallic helix coil is heat-treated for stress relief, and silicone-coated to minimize pointer vibration and maximize heat transfer and response time
- 360° groove around stem is a visual reference to show minimum immersion point
- Adjustable pan clips are standard on 18-350, 20-350 and 30-350 models with 5" and 8" stem lengths
- Made in the U.S.A.

APPLICATIONS

Used in almost every area of manufacturing, especially suited for laboratory testing and general purpose applications in the following areas:

- Laboratory
- Food & beverage processing
- Concrete
- Asphalt
- OEM equipment
- HVAC

	SERIES	SPECIFICATIONS
Case & bezel	All 350 Series	304 Stainless Steel; 316 Stainless Steel optional
Lens	14-350 All other 350 Series models	Convex Polycarbonate Instrument Glass
Pointer	All 350 Series	Aluminum, black finish
Stem diameter	All 350 Series	.150" (3.81 mm)
Accuracy	All 350 Series	±1% full scale, Grade A, ASME B40.3
Dial	All 350 Series	Anodized Aluminum with large black numbers and graduations
Wetted parts	All 350 Series	304 Stainless Steel; 316 Stainless Steel optional
Hermetic seal	All 350 Series	Per ASME B40.3 dustproof and leakproof
Bimetal coil	All 350 Series	Silicone coated helix coil on ranges below 500 °F for vibration dampening, maximum heat transfer and response time
Over temperature limits	All 350 Series	Up to 250 °F 100%; 250 °F to 550 °F 50%; 550 °F to 1,000 °F continuous use up to 800 °F; intermittent use over 800 °F
Recalibrator	All 350 Series	External reset



WARNING: This product can expose you to chemicals including Chromium (VI) and Nickel, which are known to the State of California to cause cancer and birth defects or other reproductive harm. For more information go to www.P65Warnings.ca.gov

Thermowells are recommended for pressure, corrosive fluids and high velocity applications, see pages 46-48.

ORDERING INFORMATION						
DIAL SIZES	10	1" **	18	1-3/4"	30	3"
	14	1-3/8" **	20	2"		
CASE TYPES	350	Back connection				
STEM LENGTHS	050	5" **	120	12"		
	080	8" **	180	18"		
TEMPERATURE RANGES	-100/100 F/C	-100 °F/°C to 100 °F/°C	0/250 F/C	0 °F/°C to 250 °F/°C	50/550 F/C	50 °F/°C to 550 °F/°C
	-40/160 F/C	-40 °F/°C to 160 °F/°C	20/240 F/C	20 °F/°C to 240 °F/°C	150/750 F/C	150 °F/°C to 750 °F/°C
<i>Dual Scale °F/ °C</i>	0/140 F/C	0 °F/°C to 140 °F/°C	25/125 F/C	25 °F/°C to 125 °F/°C	200/1000 F/C	200 °F/°C to 1,000 °F/°C *
(Not available on 1" model)	0/180 F/C	0 °F/°C to 180 °F/°C	50/300 F/C	50 °F/°C to 300 °F/°C		
	0/220 F/C	0 °F/°C to 220 °F/°C	50/400 F/C	50 °F/°C to 400 °F/°C		
<i>Single Scale °F</i>	-100/100 F	-100 °F to 100 °F	0/220 F	0 °F to 220 °F **	50/400 F	50 °F to 400 °F
	-50/120 F	-50 °F to 120 °F	0/250 F	0 °F to 250 °F	50/500 F	50 °F to 500 °F **
	-40/160 F	-40 °F to 160 °F **	20/240 F	20 °F to 240 °F	50/550 F	50 °F to 550 °F
	0/140 F	0 °F to 140 °F	25/125 F	25 °F to 125 °F **	150/750 F	150 °F to 750 °F **
	0/180 F	0 °F to 180 °F	50/250 F	50 °F to 250 °F	200/1000 F	200 °F to 1,000 °F *
	0/200 F	0 °F to 200 °F	50/300 F	50 °F to 300 °F		
<i>Single Scale °C</i>	-75/175 C	-75 °C to 175 °C	-10/110 C	-10 °C to 110 °C **	0/300 C	0 °C to 300 °C
	-50/100 C	-50 °C to 100 °C	0/50 C	0 °C to 50 °C **	0/400 C	0 °C to 400 °C
	-50/25 C	-50 °C to 25 °C	0/100 C	0 °C to 100 °C	100/400 C	100 °C to 400 °C
	-50/50 C	-50 °C to 50 °C	0/150 C	0 °C to 150 °C	100/550 C	100 °C to 550 °C *
	-40/70 C	-40 °C to 70 °C **	0/200 C	0 °C to 200 °C		
	-20/120 C	-20 °C to 120 °C	0/250 C	0 °C to 250 °C **		
	Consult factory for additional temperature ranges					
OPTIONS	LL	Polycarbonate Lens	PS	Pocket Sheath***	TG	Tempered Glass Lens †
	PL	Acrylic Lens	ST	Stainless Steel Tagging		

Please consult your local NOSHOK Distributor or NOSHOK, Inc. for availability and delivery information.

Note: All 316 Stainless Steel construction (case, bezel, wetted parts) is available. Please consult factory.

* Thermometers with temperature ranges 200/1000 °F and 100/500 °C are not recommended for continuous use above 800 °F/425 °C. For intermittent use only.

** 10-350 and 14-350 models are only available in these stem lengths and ranges.

*** Available for 5" or 8" stem lengths only.

† Not available on 10-350 model. Also not available with Silicone Filled (SL) option.

EXAMPLE

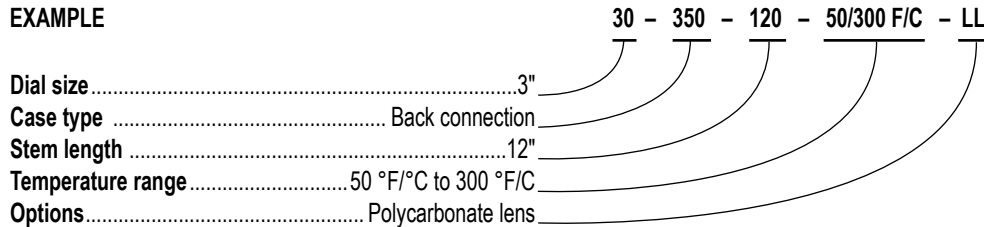

Dimensions

14-350

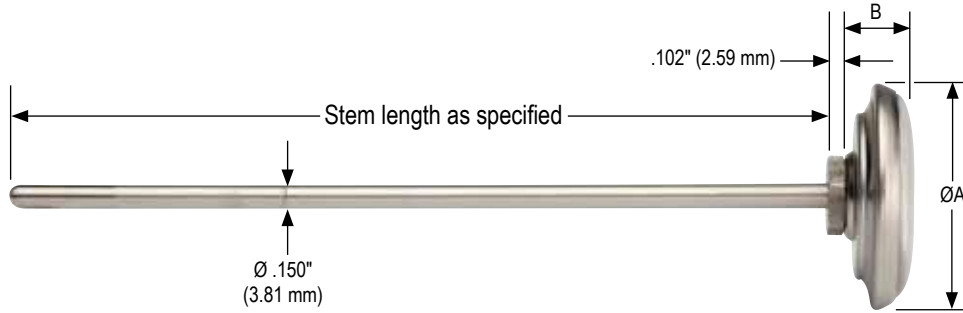

See page 19 for dimension chart.

10-350/18-350/20-350/30-350

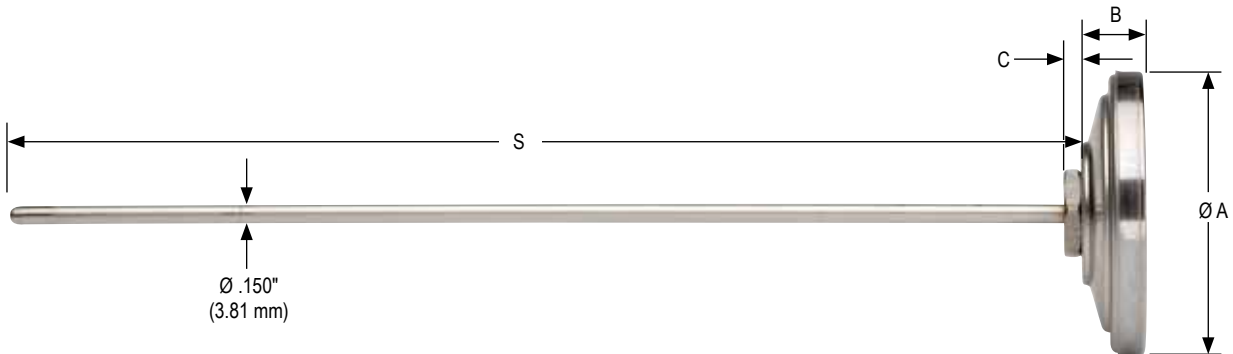

See page 19 for dimension chart.

Series	Ø A	B	C	S (Stem Length)
10-350	1.032" 26.21 mm	.350" 8.89 mm	—	As specified
14-350	1.358" 34.50 mm	.456" 11.58 mm	—	As specified
18-350	1.750" 44.45 mm	.412" 10.47 mm	.102" 2.59 mm	As specified
20-350	2.089" 53.06 mm	.438" 11.13 mm	.120" 3.05 mm	As specified
30-350	3.200" 81.28 mm	.465" 11.81 mm	.120" 3.05 mm	As specified



Pocket Sheath is available on 14-350 (shown left) and 10-350 (shown right) models, with 5" or 8" stem.

Vapor Actuated Remote

300/400/600 700/900 SERIES



- Indicates media temperature using a temperature-actuated liquid in the sensing element and a highly accurate, high quality pressure gauge
- As the media temperature increases, the capillary fill fluid vaporizes, increasing pressure in the Bourdon tube to activate the movement and pointer for proper indication
- Ranges available from -40 °F/C to 60 °F/C through 100 °F/C to 350 °F/C
- 2-1/2", 4", 4-1/2" and 6" sizes
- Brass, Stainless Steel, or Phenolic case
- Dry or liquid filled
- Bottom, back or lower back connected
- Mounting options: front or rear flange, bezel, and u-clamp
- Capillary material: Copper or Stainless Steel
- Bulb material & dimensions: Copper or Stainless Steel, 2-5/8" x 3/8" through 7-5/8" x 3/8"
- The dial scale graduations are non-linear, therefore the highest degree of accuracy and readability is found in the upper half of the scale

APPLICATIONS

- Power transformers
- Paper mills
- Refineries
- Petrochemical
- Oil and gas
- Chemical
- HVAC/R
- Food processing
- Pharmaceutical

	SERIES	SPECIFICATIONS
Lens	300, 600, 700 Series 400, 900 Series	Acrylic Instrument glass
Pointer	All	Aluminum, black finish
Accuracy	All	±2.0% full scale, Grade B, ASME B40.4
Dial	All	Aluminum, white background, dual scale, black Celsius scale and black Fahrenheit scale

For NOSHOK Vapor Remote Thermometers using 300, 600 & 900 Series Gauges:



WARNING: This product can expose you to chemicals including Lead, which is known to the State of California to cause cancer and birth defects or other reproductive harm. For more information go to www.P65Warnings.ca.gov

For NOSHOK Vapor Remote Thermometers using 400 & 700 Series Gauges:



WARNING: This product can expose you to chemicals including Chromium (VI) and Nickel, which are known to the State of California to cause cancer and birth defects or other reproductive harm. For more information go to www.P65Warnings.ca.gov

Thermowells are recommended for pressure, corrosive fluids and high velocity applications, see pages 46-48.

ORDERING INFORMATION			
300 SERIES	25-300	2-1/2", Brass case, bottom connection	25-310 2-1/2", Brass case, back connection
400 SERIES	40-400	4", all Stainless, bottom connection	40-410 4", all Stainless, back connection
	60-400	6", all Stainless, bottom connection	60-410 6", all Stainless, back connection
600 SERIES	45-640	4-1/2", Phenolic case/Brass bottom connection	
700 SERIES	45-740	4-1/2", Phenolic case/Stainless bottom connection	
900 SERIES	40-901	4", Stainless case, Brass bottom connection	40-911 4", Stainless case, Brass back connection
GAUGE FILL FLUIDS	0	Dry gauge	2 -40° service
	1	Glycerin	3 Silicone
MOUNTING OPTIONS	0	None	3 Rear flange ²
	1	Chrome front flange ¹	4 Bezel & u-clamp ³
	2	Brass front flange ¹	5 Stainless Steel front flange ⁴
TEMPERATURE RANGES	1	-40 °F/°C to 60 °F/°C	6 30 °F/°C to 180 °F/°C
	2	-20 °F/°C to 120 °F/°C	7 30 °F/°C to 240 °F/°C
	3	0 °F/°C to 250 °F/°C	8 30 °F/°C to 300 °F/°C
	4	0 °F/°C to 300 °F/°C	9 50 °F/°C to 350 °F/°C
	5	20 °F/°C to 220 °F/°C	10 100 °F/°C to 350 °F/°C
CAPILLARY TYPES/MATERIALS	1	Plain Copper	3 Plain Stainless Steel
	2	Armored Copper	4 Armored Stainless Steel
CAPILLARY LENGTH	##	Specify in feet	
BULB STYLES/MATERIALS	1	Plain Copper	3 1/2" NPT union Copper
	2	Plain Stainless Steel	4 1/2" NPT union Stainless Steel
BULB DIMENSIONS	1	2-5/8" x 3/8"	6 4" x 3/8"
	2	4-1/2" x 3/8"	7 9" x 3/8"
	3	8" x 3/8"	8 7-5/8" x 3/8"
	4	3-1/2" x 3/8"	15 6" x 1/2" ⁵
	5	6" x 3/8"	

Please consult your local NOSHOK Distributor or NOSHOK, Inc. for availability and delivery information.

* Not available for gauge sizes ≥4" or ≥16' capillary

¹ Only available on 300 Series

² Not available on 600/700 Series

³ Only available on back connection case types

⁴ Only available on 400 & 900 Series

⁵ 4" gauge or larger requires 6" bulb

EXAMPLE

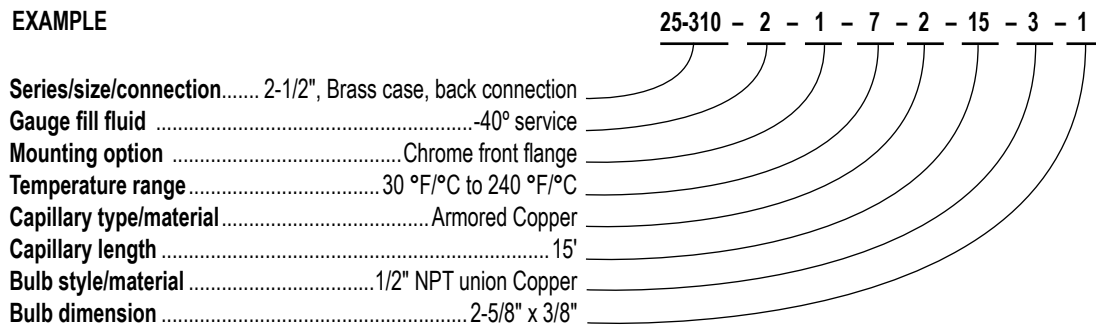

Dimensions

25-300

25-310

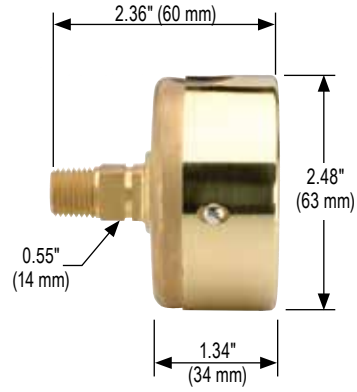
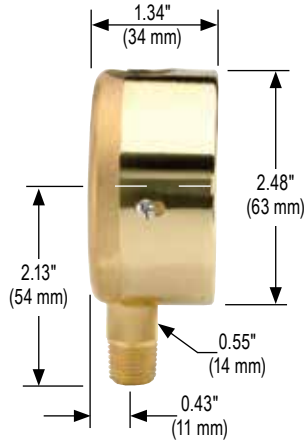

25-300 Front Flange

25-310 Front Flange

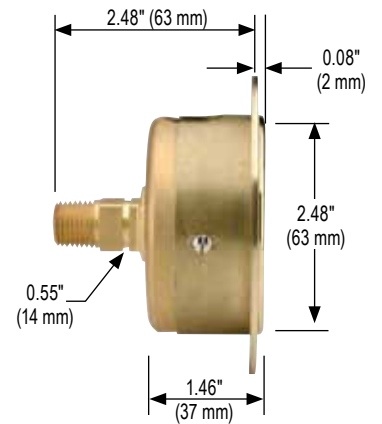
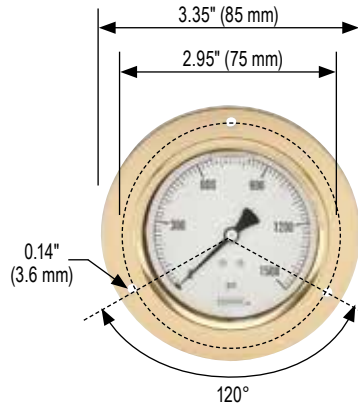
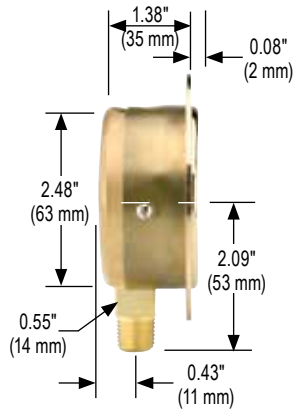
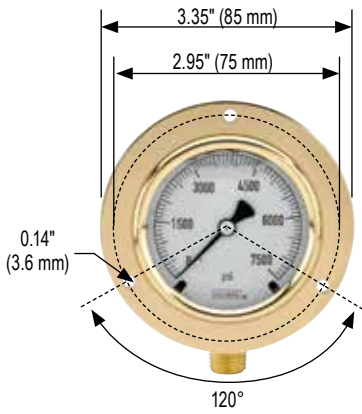

25-300 Rear Flange

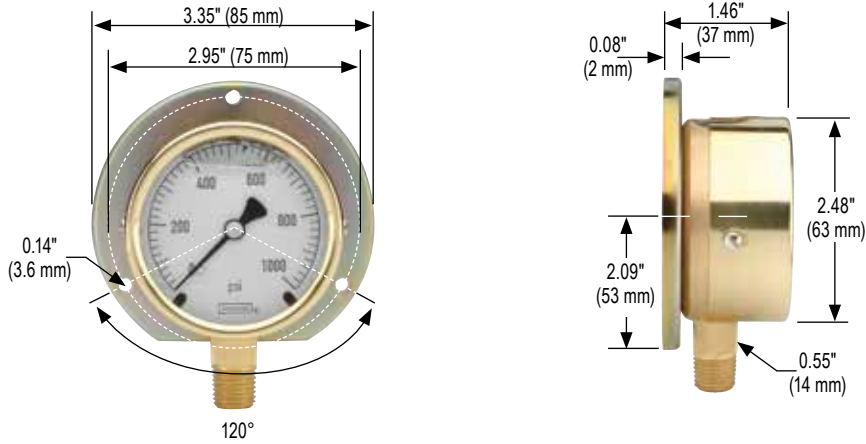

25-310 Rear Flange 25-310 Chrome Bezel with U-Clamp

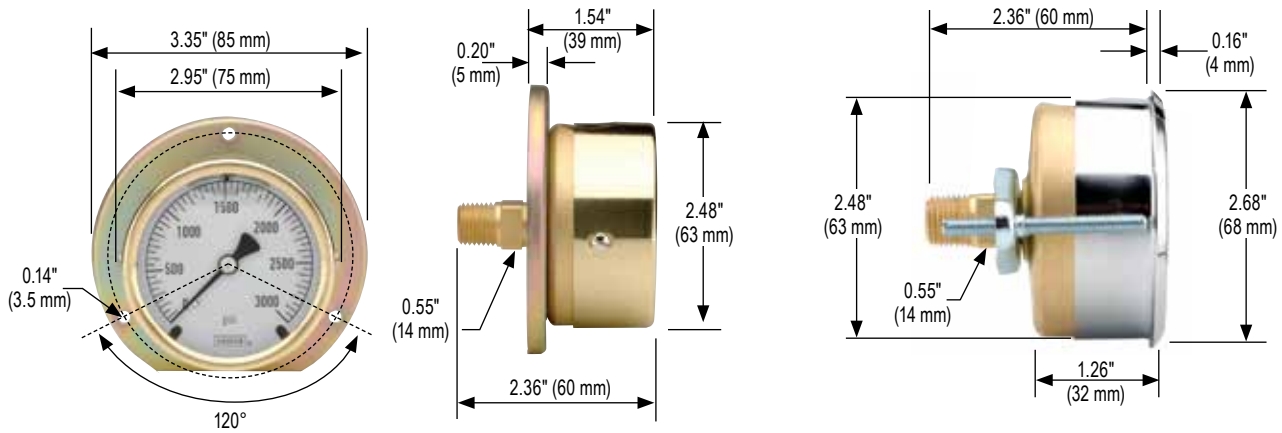

Dimensions

40-400



60-400

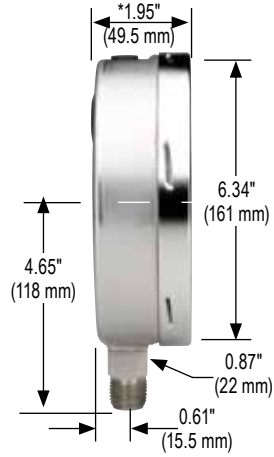

40-410

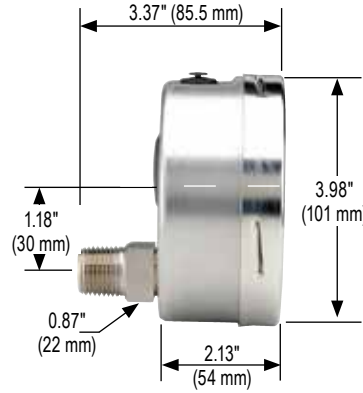

60-410

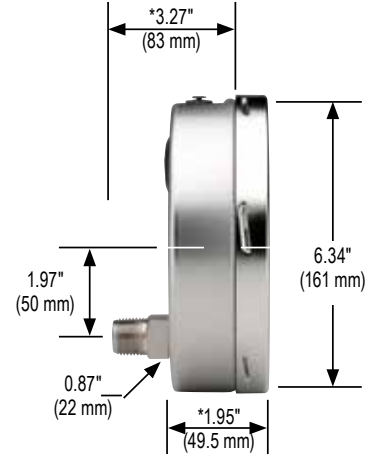

* ≥ 1,500 psi increase by 0.67" (17 mm)

* ≥ 1,500 psi increase by 0.67" (17 mm)

40-400 Front Flange

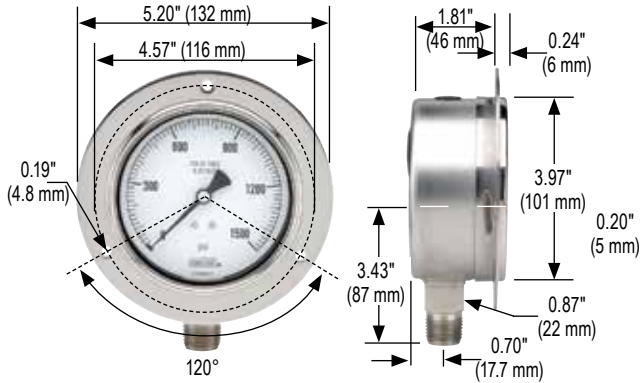

60-400 Front Flange

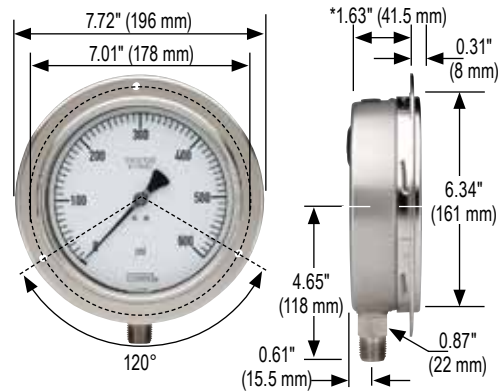

300/400/600/700/900 SERIES DIMENSIONS

40-410 Front Flange

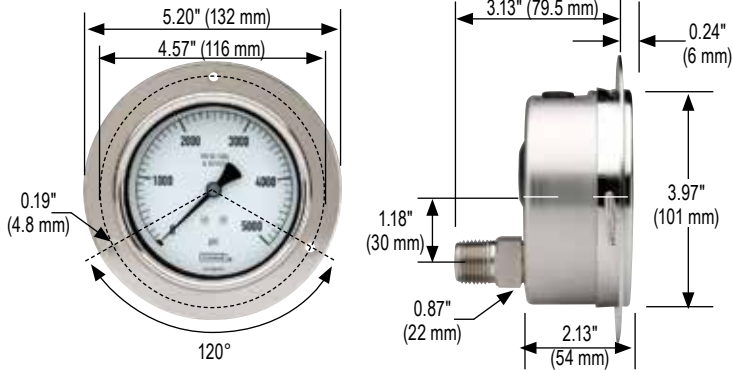

60-410 Front Flange

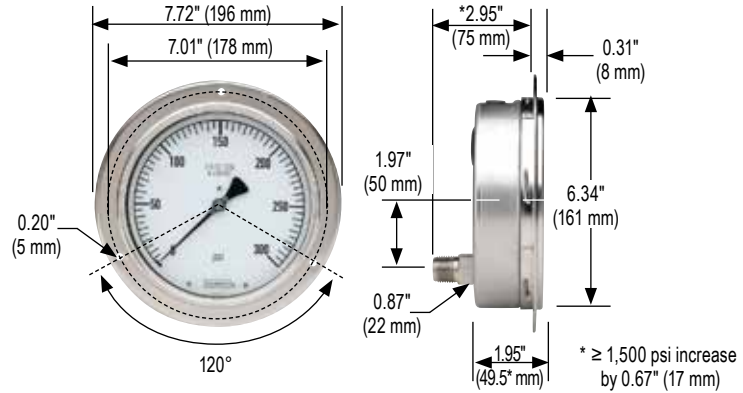

40-400 Rear Flange

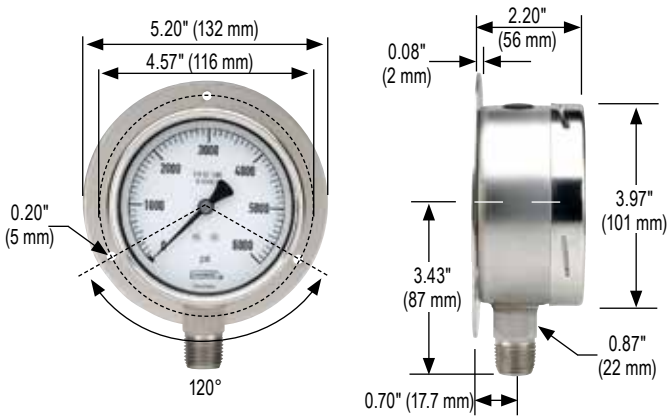

60-400 Rear Flange

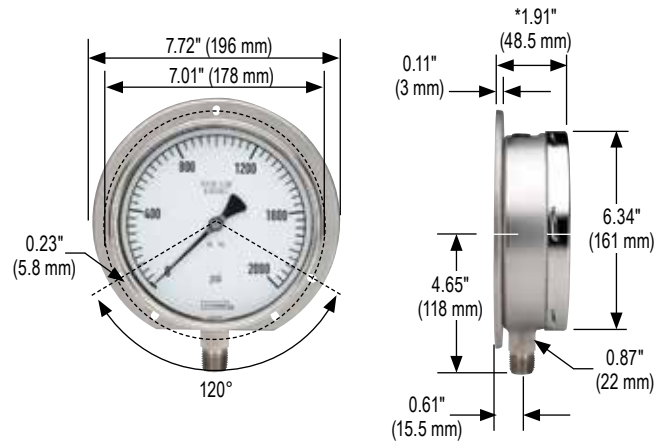

Dimensions

40-410 Rear Flange

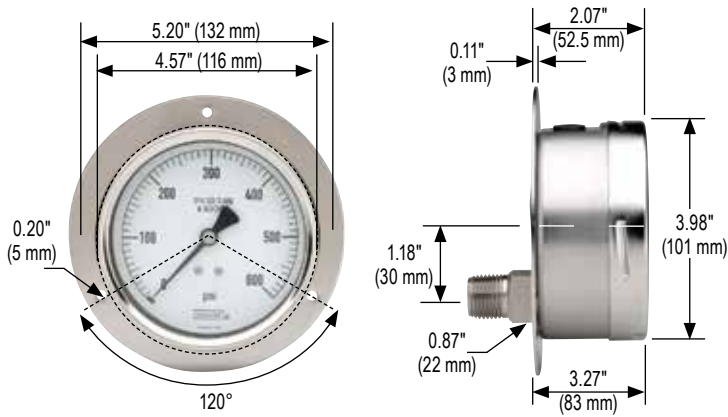

60-410 Rear Flange

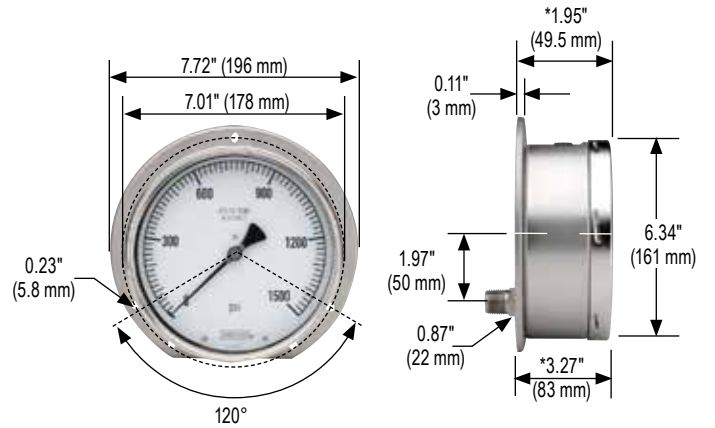

40-410/510 SS Bezel w/U-Clamp

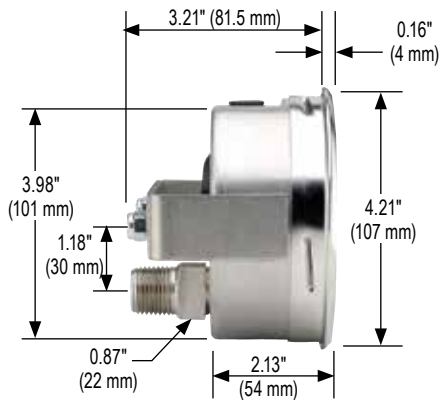

60-410 SS Bezel w/U-Clamp

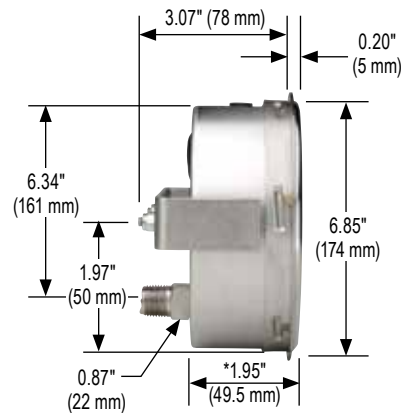

45-640 & 45-740

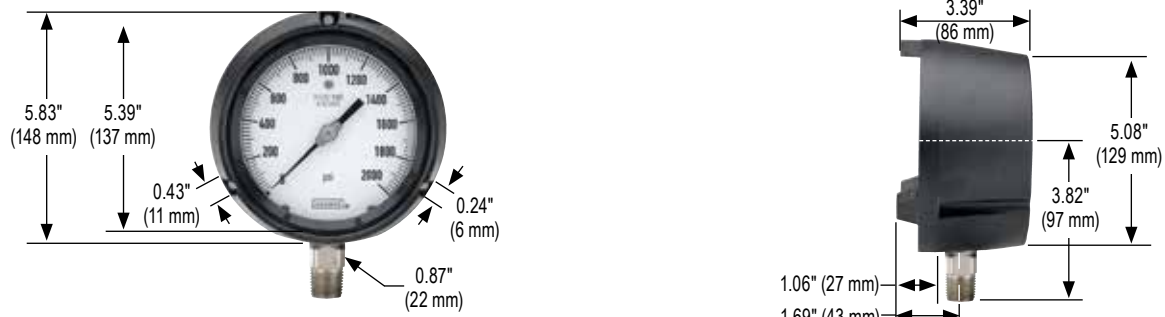

300/400/600/700/900 SERIES DIMENSIONS

40-901

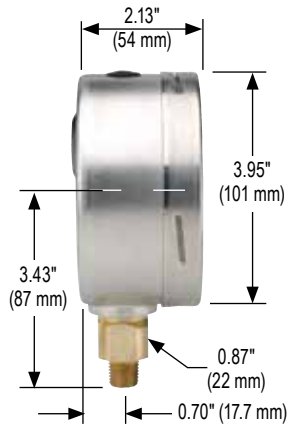

40-911

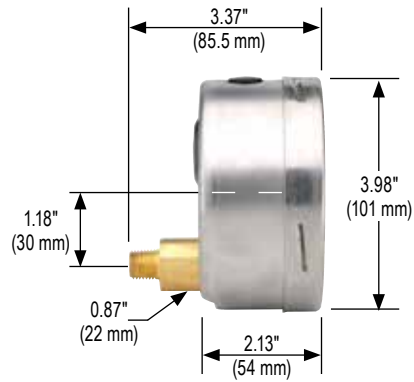

40-911 Front Flange

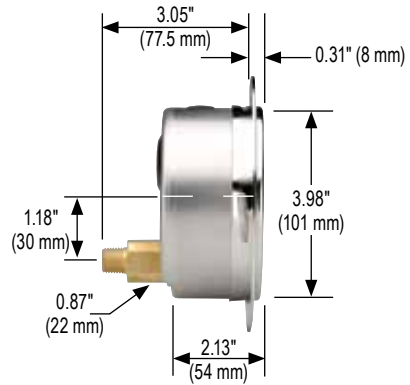
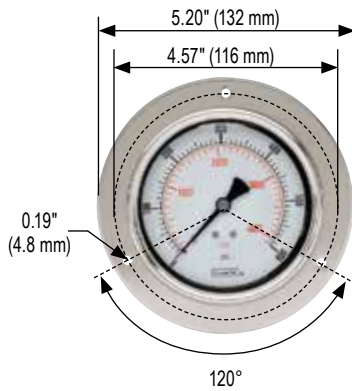

40-911 Rear Flange

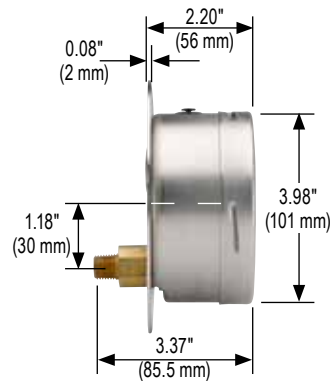
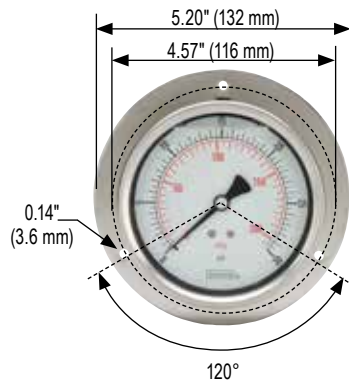

Dial Indicating Thermometer Options

ADJUSTABLE UNION CONNECTION

- Can be used to reposition the dial face for better viewing
- Also helpful when installing a thermometer where space is limited

CERTIFIED CALIBRATION

- Available on all NOSHOK thermometers
- Certified calibration provides the user with a serial numbered thermometer along with a calibration sheet against a primary temperature standard
- Traceable to the National Institute of Standards and Technology

CONNECTIONS

- In addition to our standard 1/2" NPT connection, 1/4" , 3/8" NPT and metric connections are also available
- If a special connection is required, please consult the factory
- Other options include a plain stem with an adjustable compression fitting, or left, right or top connections

GLOW DIAL (GD)

- Allows up close daylight and/or distant night time viewing
- 5" Adjustable angle or back connect
- Reflective Pointer
- Two reflective clips included to indicate custom minimum and maximum limits

LENSES

- Laminated safety glass lenses are available on all 3" and 5" NOSHOK bimetal thermometers
- Acrylic and polycarbonate lenses are available on all NOSHOK bimetal thermometers also, however they should not be used where case temperature exceeds 300 °F/150 °C

MINIMUM OR MAXIMUM INDICATING POINTER (MIP)

- The MIP allows you to view your minimum **or** maximum temperatures for visual clarification of safe operation
- Available only on 30-310 and 50-310 models



MINIMUM AND MAXIMUM INDICATING POINTER (MIP2)

- The MIP2 allows you to view your minimum **and** maximum temperatures for visual clarification of safe operation
- Available only on 30-310 and 50-310 models



MOUNTING FLANGES

- Various sizes and types of mounting flanges are available



SILICONE FILLED

- All 2", 3" and 5" NOSHOK Industrial bimetal thermometers are offered in a filled version
- For applications where severe vibration may be a factor
- Silicone dampens and lubricates the internal mechanism thus reducing pointer oscillation and premature wear
- A polycarbonate lens is standard with a silicone filled thermometer
- Maximum case temperature not to exceed 300 °F (150 °C)



SPECIAL DIALS

- Special ranges and dials with company names, company logos, part numbers, telephone numbers, or almost any custom layout is available



STEM TYPES

- The 304 Series Stainless Steel stem is welded at the tip and case for hermetic seal
- 1/4" (6.35 mm) diameter is standard for lengths up to 24" (609 mm)
- 3/8" diameter, sharp tip options and optional 316SS wetted parts are also available



800 SERIES

- Proven 100 Ω platinum resistance sensor provides reliability, stability and unbeatable performance
- Economical price
- Standard temperature ranges from -40 °F to 120 °F through 50 °F to 400 °F
- Wide variety of temperature ranges and connections
- Quick response time
- 316 Stainless Steel housing
- Burnout protection from 3.3 mA to 23 mA
- Also available with our 1800 Series attachable loop indicator
- CE compliant to suppress RFI, EMI, and ESD

APPLICATIONS

- Water systems
- Storage tanks
- Industrial machinery and machine tools
- HVAC systems
- Refrigeration systems



Also available with our 1800 Series attachable loop indicator. See www.noshok.com for details.

SPECIFICATIONS

Output signals	4 mA to 20 mA 2-wire, 0 Vdc to 5 Vdc 3-wire 0 Vdc to 10 Vdc 3-wire, 1 Vdc to 5 Vdc 3-wire
Temperature ranges	Standard ranges from -40 °F to 400 °F
Accuracy	
Measuring element	Class B per EN 60751 (IEC 751)
Output	$\pm[0.30 + 0.005 \cdot t]$ °C $\pm 0.5\%$ full scale
Sensor protection	Burnout protected from 3.3 mA to 23 mA
Power requirement*	10 Vdc to 30 Vdc (4 mA to 20 mA, 2-wire) 10 Vdc to 30 Vdc (0 Vdc to 5 Vdc, 3-wire) 10 Vdc to 30 Vdc (1 Vdc to 5 Vdc, 3-wire) 14 Vdc to 30 Vdc (0 Vdc to 10 Vdc, 3-wire)
Load limitations	$\leq (V_{Power} - 10)/0.020$ Amp for 4 mA to 20 mA output $\leq 5,000 \Omega$ for 1 Vdc to 5 Vdc output $\leq 10,000 \Omega$ for 0 Vdc to 10 Vdc output $\leq 4,500 \Omega$ for 0.5 Vdc to 4.5 Vdc output
Wetted materials	316 Stainless Steel
Housing material	316 Stainless Steel
Max. operating pressure	6 mm: 725 psi 8 mm: 1,500 psi
Ambient temperature	-40 °F to 185 °F (-40 °C to 85 °C)
Storage temperature	-40 °F to 185 °F (-40 °C to 85 °C)
Environmental rating	IP65 according to EN 60529/IEC 529
Electromagnetic rating	CE compliant to EMC norm EN 61326:1997/A1:1998 RFI, EMI and ESD protection
Electrical protection	Reverse polarity, over-voltage and short circuit protection
Weight	Approximately 4 oz.

* Unregulated



WARNING: This product can expose you to chemicals including Chromium (VI) and Nickel, which are known to the State of California to cause cancer and birth defects or other reproductive harm. For more information go to www.P65Warnings.ca.gov

Thermowells are recommended for pressure, corrosive fluids and high velocity applications, see pages 46-48.

ORDERING INFORMATION						
SERIES	800					
TEMPERATURE RANGES	-40/120	-40 °F to 120 °F	0/200	0 °F to 200 °F	25/125	20 °F to 240 °F
	0/100	0 °F to 100 °F	0/250	0 °F to 250 °F	50/300	50 °F to 300 °F
	0/140	0 °F to 140 °F	20/240	20 °F to 240 °F	50/400	50 °F to 400 °F
ACCURACY	1 Class B + (±0.5% BFSL)					
OUTPUT SIGNALS	1	4 mA to 20 mA, 2-wire	3	1 Vdc to 5 Vdc, 3-wire		
	2	0 Vdc to 5 Vdc, 3-wire	5	0 Vdc to 10 Vdc, 3-wire		
PROCESS CONNECTIONS	2	1/4" NPT Male			48	1/2" NPT Male w/adjustable compression fitting
	8	1/2" NPT Male				
ELECTRICAL CONNECTIONS	1	36" cable (connected to option 8)			14	Hirschmann connection w/ISO 4400 1/2" NPT conduit
	8	Hirschmann (DIN EN 175301-803 Form A)			25	M12 x 1 (4-pin)
STEM LENGTHS	025	2.5"			060	6"
	040	4"			120	12"
STEM DIAMETERS		6 mm			090	9"
					8	8 mm

Please consult your local NOSHOK Distributor or NOSHOK, Inc. for availability and delivery information.

EXAMPLE

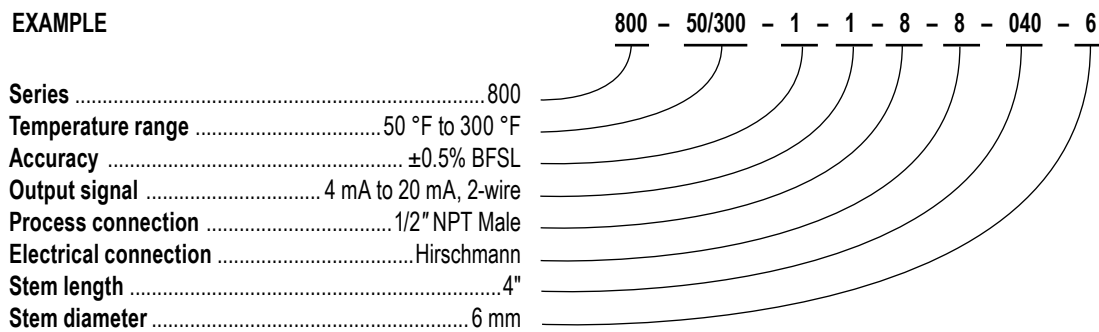

800 Series Platinum Resistance Temperature Transmitter

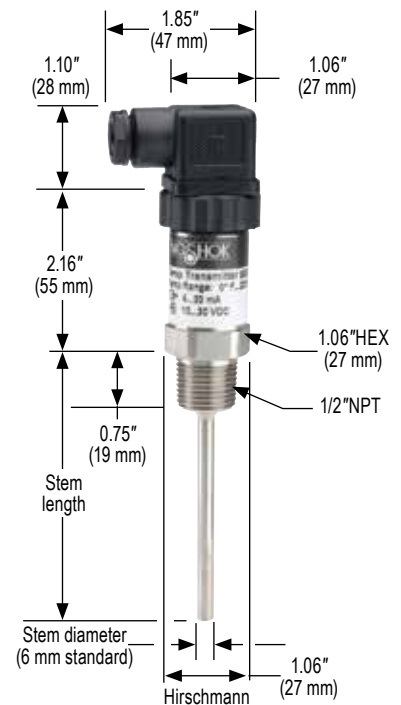
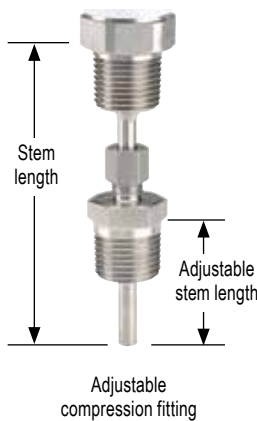

2-WIRE WIRING

Wiring	Hirschmann	Cable
+ Supply	1	Red
+ Output	2	Black

3-WIRE WIRING

Wiring	Hirschmann	Cable
+ Supply	1	Red
Common	2	Black
+ Output	3	White



810 SERIES

- Compact size, economical price
- Proven 100 Ω platinum resistance sensor provides reliability, stability and unbeatable performance
- Standard temperature ranges from -25 °F to 125 °F through 0° F to 250 °F
- 4 mA to 20 mA transmitter included
- 316 Stainless Steel housing
- CE compliant to suppress RFI, EMI, and ESD

SPECIFICATIONS

Output signal	4 mA to 20 mA, 2-wire	
Temperature ranges	Standard ranges from -25 °F to 250°F (-30 °C to 120°C)	
Accuracy	Measuring element	PT100 Class B $\pm[0.30 + 0.005* t]$ °C
	Output	$\pm 1.5\%$ full scale
Failure signal	Sensor burnout	23 mA
	Sensor short circuit	3.3 mA
Power requirement*	10 Vdc to 36 Vdc	
Load limitations	$\leq (V_{power} - 10)/0.020$ A	
Wetted materials	316 Stainless Steel	
Housing material	316 Stainless Steel	
Ambient temperature	Maximum 185 °F (85 °C)	
Storage temperature	-40°F to 185 °F (-40°C to 85 °C)	
Electromagnetic rating	CE compliant to EMC norm DIN EN 61326 RFI, EMI and ESD protection	
Electrical protection	Reverse polarity, over-voltage and short circuit protection	
Pressure rating	8,700 psi (600 bar) ¹	

* Unregulated

¹ Pressure rating may vary based on the process medium, temperature and flow rate.

APPLICATIONS

- Mobile hydraulics
- Automotive
- Heat exchangers
- HVAC
- Transportation
- Refrigeration controls



WARNING: This product can expose you to chemicals including Chromium (VI) and Nickel, which are known to the State of California to cause cancer and birth defects or other reproductive harm. For more information go to www.P65Warnings.ca.gov

Thermowells are recommended for pressure, corrosive fluids and high velocity applications, see pages 46-48.

ORDERING INFORMATION			
SERIES	810		
TEMPERATURE RANGES	-25/125 -25 °F to 125 °F	0/140 0 °F to 140 °F	0/250 0 °F to 250 °F
	Custom ranges available on request (54 °F minimum span)		
ACCURACY	1 Class B + (±1.5% BFSL)		
OUTPUT SIGNAL	1 4 mA to 20 mA, 2-wire		
PROCESS CONNECTION	2 1/4" NPT Male		
ELECTRICAL CONNECTION	25 M12 x 1 (4-pin)		
STEM LENGTHS *	020 2"	030 3"	040 4" 060 6"
STEM DIAMETER	6 6 mm		

Please consult your local NOSHOK Distributor or NOSHOK, Inc. for availability and delivery information.

*Consult factory for additional stem length options.

EXAMPLE

Series 810
 Temperature range -25 °F to 125 °F
 Accuracy Class B (±1.5% BFSL)
 Output signal 4 mA to 20 mA, 2-wire
 Process connection 1/4" NPT Male
 Electrical connection M12 x 1 (4-pin)
 Stem length 2"
 Stem diameter 6 mm

810 - -25/125 - 1 - 1 - 2 - 25 - 020 - 6

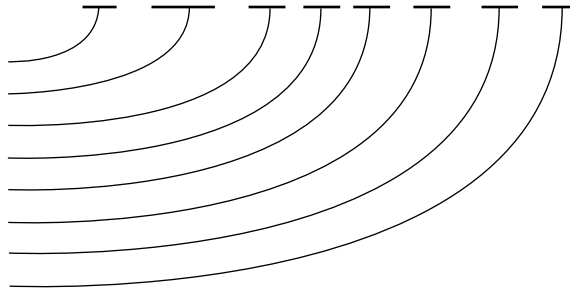

810 Series Compact OEM Temperature Transmitter



**Wiring -
M12 x 1 (4-pin)
round connector**

Current output, 2 wire

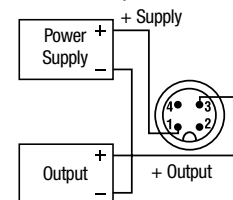

Digital Temperature Indicators



820/821 SERIES

- Large 4-digit LED display
- Field re-programmable with optional PC interface module and software
- Software includes a security feature to prevent accidental re-programming
- 4 mA to 20 mA programmable linearized output signal
- Utilizes a self-calibration feature for accurate and stable performance
- Optional fully programmable switch output; relay or transistor
- Utilizes a PT100 Ω RTD Class A element for temperature sensing
- M12 x 1 (5-pin) plug or 36" integral cable electrical connection
- IP 65 / NEMA 4 rated environmental protection
- All 316 Stainless Steel construction
- Easy installation with various mounting configurations

SPECIFICATIONS

Temperature ranges	Standard ranges from -325 °F to 1,100 °F (-200 °C to 600 °C) Customer rescalable with optional PC interface and software
Temperature sensor	RTD (PT100 DIN EN 60751, Class A)
Housing material	316 Stainless Steel
Probe material	316 Stainless Steel standard
Maximum pressure	500 psig (on probe)
Power requirement	9-36 Vdc, polarity protected
Supply effect	0.005%/V
Power consumption	15 mA @ 24 Vdc + output current – 950 mW max. 20 mA @ 24 Vdc for PNP output – 500 mW max. 20 mA @ 24 Vdc + sourcing current for NPN output 50 mA @ 24 Vdc for relay output – 1200 mW max.
Current output	4 mA to 20 mA (3-wire configuration) linear to temperature
Max load on current output	(Vsupply-9V) / 20 mA, Ω
Optional switching output	Relay SPDT 0.5A @ 240 Vac or Transistor NPN (max 100 mA source) or Transistor PNP (max 100 mA sink)
Optional switching logic	N.C. or N.O. software selectable
Optional switching ranges	Customer programmable between -325 °F to 1,100 °F (-200 °C to 600 °C)
Isolation	500 Vdc input /output (between probe and output signal)
Electrical connection	M12 x 1 (5-pin) or integral cable
Hysteresis	1% of range standard; customer programmable optional
Accuracy	$\leq 0.22\%$ full scale; $\leq 0.1\%$ full scale optional
Open circuit detection	Upscale (22 mA) or downscale (2.5 mA) current output. Error message on LED display
Warm-up	30 seconds
Response time	0.5 sec to 30 sec (software selectable)
Display	4-digit LED, decimal point selectable by software
Display resolution	$\pm 0.02\%$ F.S. ± 1 digit
RFI effect	1% or less typical
Temperature ranges	Ambient -40 °F to 176 °F (-40 °C to 80 °C) Effect <0.01% FS/°C Storage -58 °F to 185 °F (-50 °C to 85 °C)
Environmental protection	NEMA 4/ IP 65

APPLICATIONS

- Replacement for bimetal, liquid bulb and glass thermometers
- Pharmaceutical
- Food preparation
- Utilities and municipal refineries
- Chemical and petrochemical plants
- Paper mills
- Hydraulics

Thermowells are recommended for pressure, corrosive fluids and high velocity applications, see pages 46-48.



WARNING: This product can expose you to chemicals including Chromium (VI) and Nickel, which are known to the State of California to cause cancer and birth defects or other reproductive harm. For more information go to www.P65Warnings.ca.gov

ORDERING INFORMATION						
SERIES	820 Bottom connection	821 Back connection				
ACCURACY	1 ≤0.22% full scale	2 ≤0.1% full scale				
OUTPUT	1 4 mA to 20 mA					
BURNOUT	U Upscale	D Downscale				
PROCESS CONNECTIONS	0 None	8 1/2" NPT Male				
	2 1/4" NPT Male	48 1/2" NPT Male w/sliding compression fitting*				
TEMPERATURE RANGES	-50/120 -50 °F to 120 °F	-50/400 -50 °F to 400 °F	32/200 32 °F to 200 °F	32/400 32 °F to 400 °F		
	-50/300 -50 °F to 300 °F	32/120 32 °F to 120 °F	32/300 32 °F to 300 °F			
ELECTRICAL CONNECTIONS	36 Integral cable 36"	48 M12 x 1 (5-pin)				
STEM LENGTHS	025 2.5"	060 6"	120 12"	180 18"		
	040 4"	090 9"	150 15"	240 24"		
STEM DIAMETERS	2 1/4"	3 3/8"	4 1/2"	6 6 mm		

Please consult your local NOSHOK Distributor or NOSHOK, Inc. for availability and delivery information.

* Add 2" to stem length for this option.

EXAMPLE

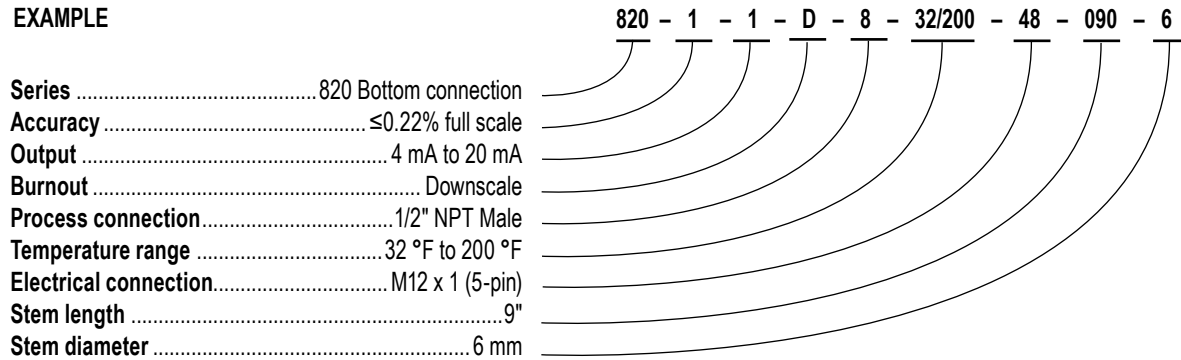

820 Series

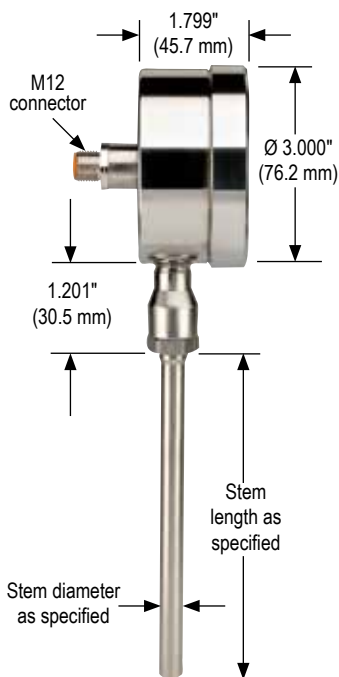

821 Series

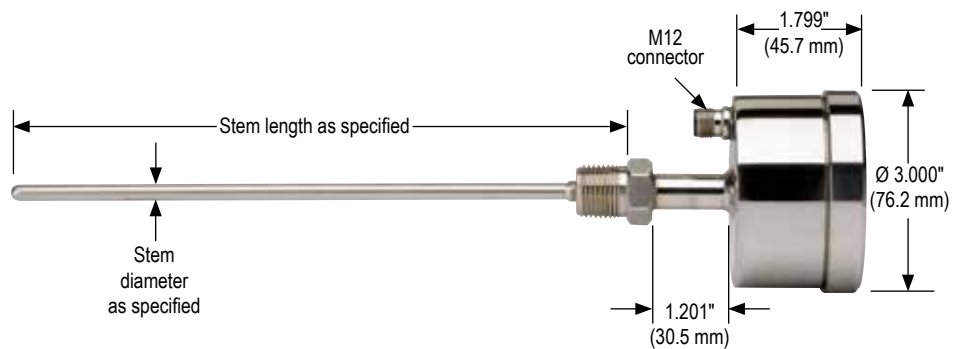

Digital Temperature Indicators, Battery Powered



822/823 SERIES

- 5 year minimum battery life
- Large 4-digit LCD display
- Utilizes a PT100 Ω RTD Class A element for temperature sensing
- IP 65 / NEMA 4 rated environmental protection
- All 316 Stainless Steel construction
- Easy installation with various mounting configurations

APPLICATIONS

- Replacement for bimetal, liquid bulb and glass thermometers
- Pharmaceutical
- Food preparation
- Utilities and municipal refineries
- Chemical and petrochemical plants
- Paper mills
- Hydraulics

SPECIFICATIONS

Temperature ranges	Standard ranges from -58 °F to 392 °F (-50 °C to 200 °C)
Temperature sensor	RTD (PT100 DIN EN 60751, Class A)
Housing material	316 Stainless Steel
Probe material	316 Stainless Steel standard
Maximum pressure	500 psig (on probe)
Power requirement	Lithium battery (3.6 V)
Supply effect	0.005%/V
Accuracy	$\leq 0.22\%$ full scale; $\leq 0.1\%$ full scale optional
Display	4-digit LCD
Display resolution	$\pm 0.02\%$ F.S. ± 1 digit
RFI effect	1% or less typical
Temperature ranges	Ambient -40 °F to 176 °F (-40 °C to 80 °C) Effect <0.01% FS/ °C Storage -58 °F to 185 °F (-50 °C to 85 °C)
Environmental protection	NEMA 4/ IP 65

Thermowells are recommended for pressure, corrosive fluids and high velocity applications, see pages 46-48.



WARNING: This product can expose you to chemicals including Chromium (VI) and Nickel, which are known to the State of California to cause cancer and birth defects or other reproductive harm. For more information go to www.P65Warnings.ca.gov

ORDERING INFORMATION			
SERIES	822 Bottom connection	823 Back connection	
ACCURACY	1 ≤0.22% full scale	2 ≤0.1% full scale	
PROCESS CONNECTIONS	0 None	8 1/2" NPT Male	
	2 1/4" NPT Male	48 1/2" NPT Male w/sliding compression fitting*	
TEMPERATURE RANGE	-58/392 -58 °F to 392 °F	-50/200C -50 °C to 200 °C	
STEM LENGTHS **	025 2.5"	060 6"	120 12"
	040 4"	090 9"	150 15"
STEM DIAMETERS	2 1/4"	4 1/2"	8 8 mm
	3 3/8"	6 6 mm	

Please consult your local NOSHOK Distributor or NOSHOK, Inc. for availability and delivery information.

* Add 2" to stem length for this option.

** Consult factory for additional stem length options.

EXAMPLE

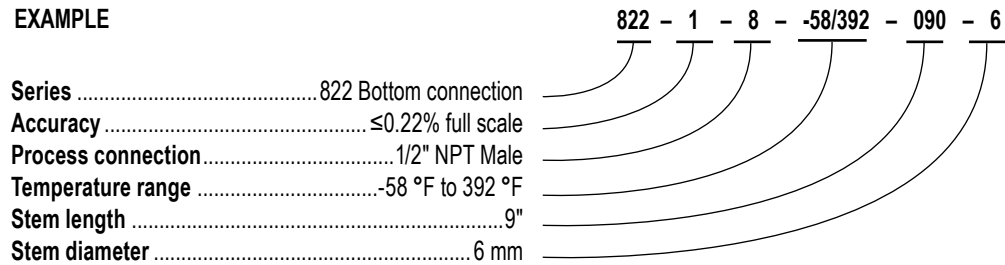

822 Series **823 Series**

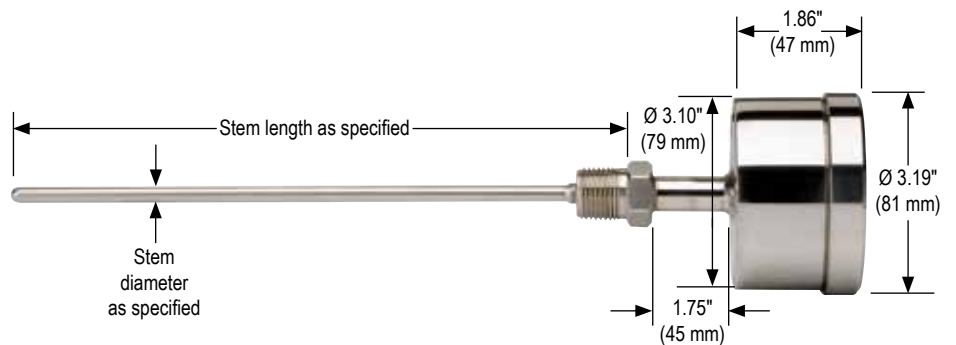
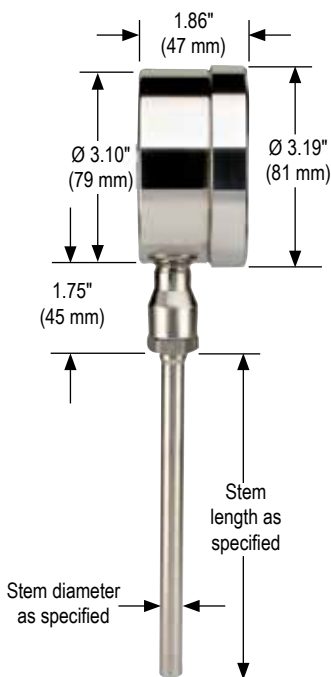



850 SERIES

- Utilizes PT1000 technology for continuous temperature monitoring, electronic temperature switching, and transmission of analog output while providing local digital indication
- Allows for one or two switching outputs as well as optional current and voltage outputs
- Three buttons on top allow simple adjustment of the temperature set points, reset points, switching functions and the measuring range of the optional analog output
- 1/2" NPT Male standard connection
- A variety of stem lengths are available for maximum versatility; also available with adjustable insertion lengths via the sliding compression fitting
- Durable stainless steel housing and wetted parts
- Display and electrical connection can be rotated independently
- RoHS compliant

SPECIFICATIONS

Temperature ranges	Standard -4 °F to 176 °F (-20 °C to 80 °C) Optional -4 °F to 248 °F (-20 °C to 120 °C) Selectable display for °F or °C
Temperature sensor	Platinum resistor (PT1000 2-wire, DIN EN 60751 Class A)
Wetted materials	316Ti stainless steel
Housing material	304 Stainless steel
Max. operating pressure	2,000 psi (1/2" NPT Male fixed process connection); 725 psi (1/2" NPT Male sliding compression fitting process connection)
Power requirement*	15 Vdc to 35 Vdc
Signal output adjustment	Zero point: 0-25% of span Full scale: 75-100% of span
Switch points	Individually adjustable via external control keys
Number	1 or 2 (PNP)
Function	N.O. / N.C.; windows-and hysteresis function freely adjustable
Adjustment accuracy	≤ 0.5% of span
Switch rating	Max. 250 mA
Electrical connection	M12 x 1 (4-pin), M12 x 1 (5-pin)
Accuracy	
Analog signal	≤ ±0.5% of span + temperature sensor error
Switching output	≤ ±0.8% of span + temperature sensor error
Display	≤ ±(0.8% of span + temperature sensor error) ±1 digit
Temperature sensor	For °F: ±[1.8*(0.15 + 0.002 (t - 32) / 1.8)] For °C: ±(0.15 K + 0.002 t) per EN 60751
Display	14 segment-LED, red 4-digit, height 0.35"
Environmental protection	IP65 and IP67 (IEC 60529)

* Unregulated

APPLICATIONS

- Mechanical engineering
- Heating and cooling circuits
- Air conditioning technology
- Plant construction
- Environmental technology

Thermowells are recommended for pressure, corrosive fluids and high velocity applications.

ORDERING INFORMATION					
SERIES	850				
SWITCH FUNCTIONS	1	2 N.O. or 2 N.C. switch (PNP *)		4	2 N.O. or 2 N.C. switch (PNP*) with 4 mA to 20 mA 3-wire analog output **
	2	1 N.O. or 1 N.C. switch (PNP *) with 4 mA to 20 mA 3-wire analog output		5	2 N.O. or 2 N.C. switch (PNP*) with 0 Vdc to 10 Vdc 3-wire output) **
	3	1 N.O. or 1 N.C. switch (PNP *) with 0 Vdc to 10 Vdc 3-wire output			
PROCESS CONNECTIONS	2	1/4" NPT Male		47	1/4" NPT Male sliding compression fitting
	8	1/2" NPT Male		48	1/2" NPT Male sliding compression fitting
TEMPERATURE RANGES	-4/176	-4 °F to 176 °F (-20 °C to 80 °C)		-4/248	-4 °F to 248 °F (-20 °C to 120 °C) †
ELECTRICAL CONNECTION	2	M12 x 1 (4-pin)		3	M12 x 1 (5-pin, 2 switch and output)
STEM LENGTHS	25mm	25 millimeters ***		100mm	100 millimeters
	50mm	50 millimeters ***		150mm	150 millimeters
STEM DIAMETERS	250mm	250 millimeters		350mm	350 millimeters
	6	6 mm			

Please consult your local NOSHOK Distributor or NOSHOK, Inc. for availability and delivery information.

* NPN available, consult factory

** Available only with M12 x 1 (5-pin) connector

*** Not available with sliding compression fitting

† Available only with sliding compression fitting process connection and stem lengths ≥100 mm

EXAMPLE

Series 850
 Switch function 2 N.O. or 2 N.C. (PNP)
 Process connection 1/4" NPT Male
 Temperature range -4 °F to 176 °F
 Electrical connection M12 x 1 (4-pin)
 Stem length 100 millimeters
 Stem diameter 6 mm

850 - 1 - 2 - -4/176 - 2 - 100mm - 6

850 Series

Tapered Thread

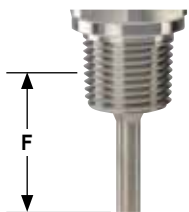

F						
in	.98	1.97	3.94	5.91	9.84	13.8
m	25	50	100	150	250	350

1 switching output (M12 x 1) with 4 mA to 20 mA signal ††

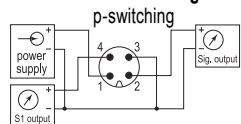

2 switching output (M12x1) with 4 mA to 20 mA signal ††

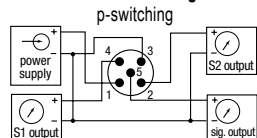

Sliding Compression Fitting with Tapered Thread

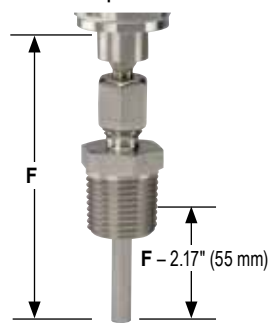

F				
in	3.94	5.91	9.84	13.8
mm	100	150	250	350

2 switching output (M12 x 1) p-switching

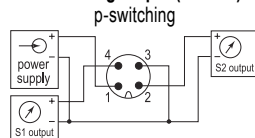

†† Also applies to 0 Vdc to 10 Vdc output

Dimensions inches (mm) with circular connector M12 x 1 (4-pin and 5-pin)

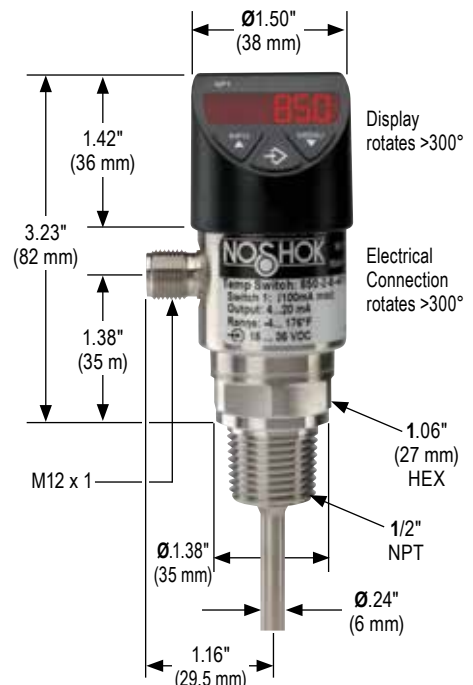

Industrial RTD, Probe Type

900 SERIES



- General purpose RTD probe with PVC or PTFE lead wires
- Adjustable and welded fittings available
- Ideal for OEM applications
- PVC or PTFE jacketed lead wires are available
- A variety of fitting sizes and probe diameters are available
- RTD PT100 Ω standard, others available
- 2, 3 or 4-wire circuit types
- Isolation to 500 Vdc
- Custom designs available

APPLICATIONS

- Chemical processing
- Textile production
- Automotive
- Plastics processing
- HVAC

SPECIFICATIONS

Temperature ranges	-50 °F to 400 °F (-50 °C to 200 °C) -50 °F to 750 °F (-50 °C to 400 °C) -330 °F to 1,100 °F (-200 °C to 600 °C)
Sheath material	316 Stainless Steel
Finish (standard)	32 micro-inches maximum
Pressure rating	500 psi (34.5 bar), tube only
RTD element	PT100 Ω @ 32 °F (0 °C), $\alpha=0.00385$ IEC 751
Lead wires	Stranded 22 AWG standard, PVC or PTFE insulation
Self-heating	50 mW / °C typical in moving water
Insulation resistance	Single element probes: 100 mega Ω /min. at 500 Vdc, leads to case Dual element probes: 100 mega Ω /min. at 100 Vdc, between element and leads to case
Transition	Sheath to wire transition max. temperature 266 °F (130 °C)



WARNING: This product can expose you to chemicals including Chromium (VI) and Nickel, which are known to the State of California to cause cancer and birth defects or other reproductive harm. For more information go to www.P65Warnings.ca.gov

Thermowells are recommended for pressure, corrosive fluids and high velocity applications, see pages 46-48.

ORDERING INFORMATION			
SERIES	900		
TEMPERATURE RANGES	-50/400 -50 °F to 400 °F	-330/1100 -330 °F to 1,100 °F	
	-50/750 -50 °F to 750 °F		
ACCURACIES	1 ±0.12% (±0.3 °C) at 0 °C, Class B	3 ±0.04% (±0.1 °C) at 0 °C, Class AA	
	2 ±0.06% (±0.15 °C) at 0 °C, Class A		
ELEMENT TYPES	C PT100 Ω at 0 °C	M PT1000 Ω at 0 °C	
CIRCUIT TYPES	1 Single, 2-wire	3 Single, 4-wire	5 Dual, 3-wire
	2 Single, 3-wire	4 Dual, 2-wire	6 Dual, 4-wire
PROCESS CONNECTIONS	0 None	8 1/2" NPT Male	
	1 1/8" NPT Male	48 1/2" NPT Male w/sliding compression fitting**	
	2 1/4" NPT Male	61 Spring loaded 1/2" NPT **,**	
ELECTRICAL CONNECTIONS	6 1/2" NPT conduit with 36" cable	48 M12 x 1 (5-pin) *	
	36 Integral cable 36"	49 3-pin RTD plug	
	37 1/2" NPT conduit with 6" flying leads	50 M12 x 1 (8-pin)	
STEM LENGTHS	025 2.5"	090 9"	180 18"
	040 4"	120 12"	240 24"
	060 6"	150 15"	
STEM DIAMETERS	1 1/8"	3 3/8"	6 6 mm
	2 1/4"	4 1/2"	

Please consult your local NOSHOK Distributor or NOSHOK, Inc. for availability and delivery information.

* Single circuit types only

** Add 2" to stem length for this option. If installing with thermowells, Process Connection option 48 or 61 must be selected.

*** Only available with Electrical Connection options 6 & 37

EXAMPLE

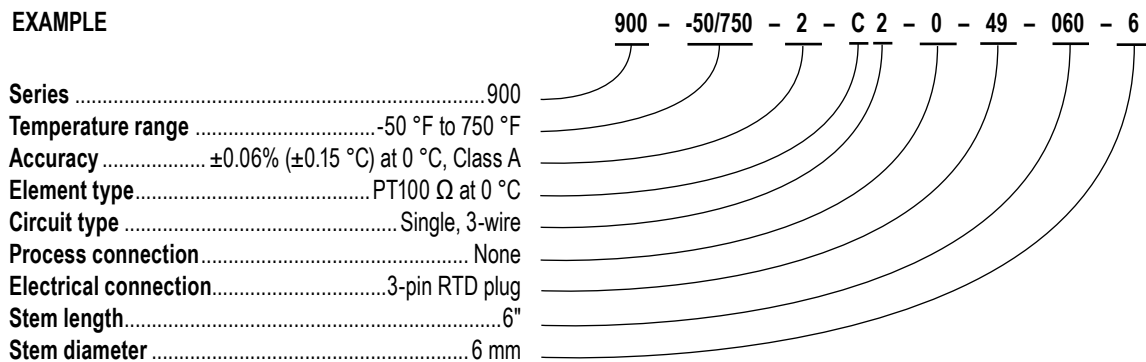

1/2" Conduit With Cable

M12 x 1 (5-pin)

Integral Cable 36"

1/2" NPT w/Flying Leads

RTD Plug

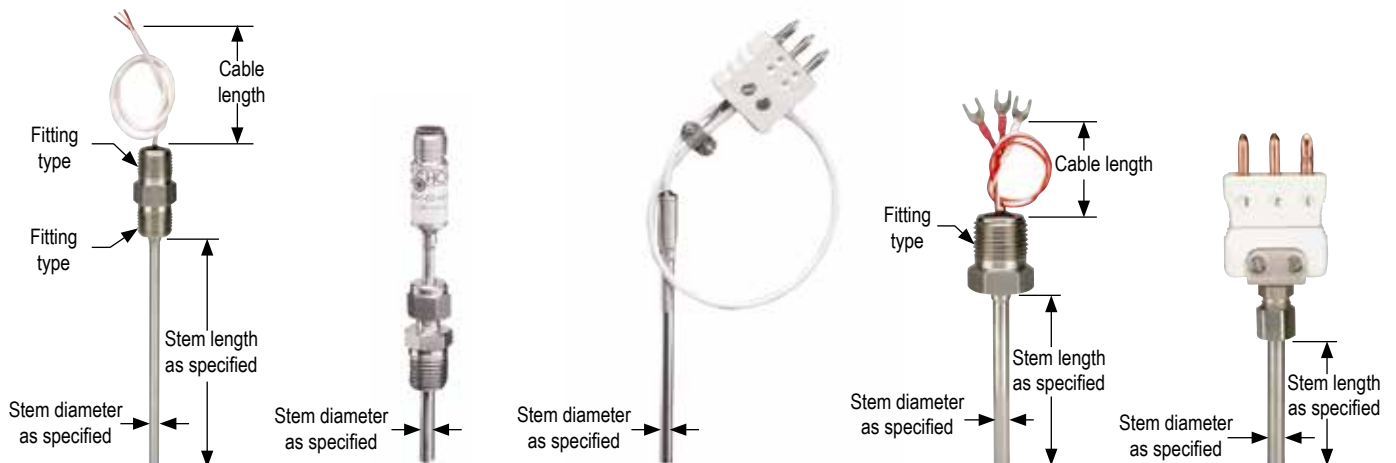

910/915 SERIES



- Standard head-type RTD assembly
- A variety of head types are available
- Factory Mutual and Canadian Standards approved explosion proof models available
- Transmitter available, fits standard heads
- Probe welded to fitting or spring loaded
- If used in conjunction with a thermowell, probe can be replaced in some models without possibility for leakage
- Process fitting 1/2" NPT standard, others available
- RTD PT100 Ω standard, others available
- 2, 3 or 4-wire circuit types
- Isolation to 500 Vdc

SPECIFICATIONS

Temperature ranges	-50 °F to 400 °F (-50 °C to 200 °C) -50 °F to 750 °F (-50 °C to 400 °C) -330 °F to 1,100 °F (-200 °C to 600 °C)
Sheath material	316 Stainless Steel
Finish (standard)	32 micro-inches maximum
Pressure rating	500 psi (34.5 bar), tube only
RTD element	PT100 Ω @ 32 °F (0 °C), $\alpha=0.00385$ IEC 751
Lead wires	Stranded 22 AWG standard, PVC or PTFE insulation
Self-heating	50 mW / °C typical in moving water
Insulation resistance	Single element probes: 100 mega Ω /min. at 500 Vdc, leads to case Dual element probes: 100 mega Ω /min. at 100 Vdc, between element and leads to case
Environmental protection	A1/A2: NEMA 4 P1 & S1/S2: NEMA 4X
Transition	Sheath to wire transition max. temperature 266 °F (130 °C)

APPLICATIONS

- Industrial boilers
- Petrochemical
- Exhaust gas monitoring
- Food processing



WARNING: This product can expose you to chemicals including Chromium (VI) and Nickel, which are known to the State of California to cause cancer and birth defects or other reproductive harm. For more information go to www.P65Warnings.ca.gov

Thermowells are recommended for pressure, corrosive fluids and high velocity applications, see pages 46-48.

ORDERING INFORMATION			
SERIES	910 Fixed RTD	915 Spring-loaded RTD	
TEMPERATURE RANGES	-50/400 -50 °F to 400 °F -50/750 -50 °F to 750 °F	-330/1100 -330 °F to 1,100 °F	
ACCURACIES	1 ±0.12% (±0.3 °C) at 0 °C, Class B 2 ±0.06% (±0.15 °C) at 0 °C, Class A	3 ±0.04% (±0.1 °C) at 0 °C, Class AA	
ELEMENT TYPES	C PT100 Ω at 0 °C	M PT1000 Ω at 0 °C	
CIRCUIT TYPES	1 Single, 2-wire 2 Single, 3-wire	3 Single, 4-wire 4 Dual, 2-wire	5 Dual, 3-wire 6 Dual, 4-wire
OPTIONAL TRANSMITTER/ OUTPUT	1U 4 mA to 20 mA, 2-wire, upscale burnout 1D 4 mA to 20 mA, 2-wire, downscale burnout 2 0 Vdc to 5 Vdc, 3-wire	3 1 Vdc to 5 Vdc, 3-wire 5 0 Vdc to 10 Vdc, 3-wire	
PROCESS CONNECTIONS	0 None 2 1/4" NPT Male	8 1/2" NPT Male	
ELECTRICAL CONNECTIONS	23 Connection head w/ 1/2" NPT conduit	45 Connection head with 3/4" NPT conduit	
ELECTRICAL CONNECTION MATERIALS	A1 Aluminum cast A2 Aluminum cast, explosion proof*	P1 PP, white S1 Stainless Steel cast	S2 Stainless Steel cast, explosion proof*
STEM LENGTHS	025 2.5" 040 4" 060 6"	090 9" 120 12" 150 15"	180 18" 240 24"
STEM DIAMETERS	1 1/8" 2 1/4"	3 3/8" 4 1/2"	6 6 mm

Please consult your local NOSHOK Distributor or NOSHOK, Inc. for availability and delivery information.

* Factory Mutual and Canadian Standards approved explosion proof Class I, Division I, Groups B, C and D; Class II, Division I, Groups E, F and G

EXAMPLE

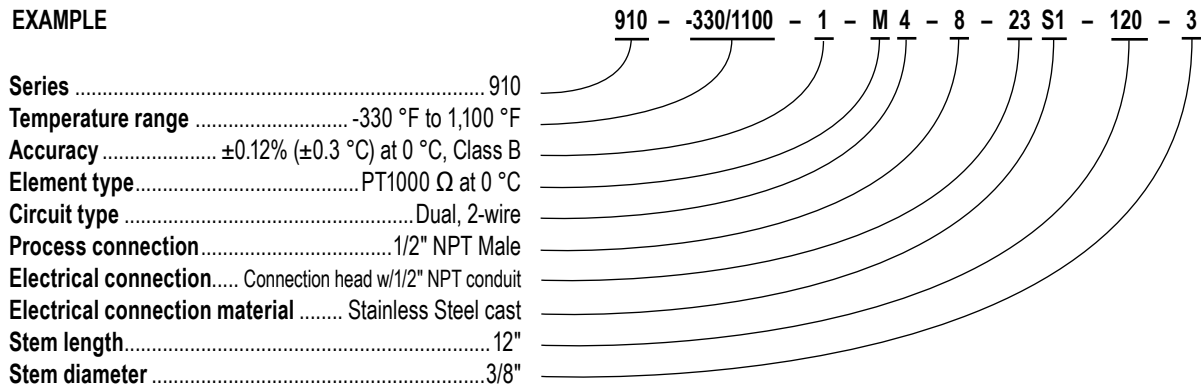

Aluminum Cast (A1/A2)

Polypropylene (P1)

Stainless Steel Cast (S1/S2)

NEMA 4

NEMA 4X

NEMA 4X

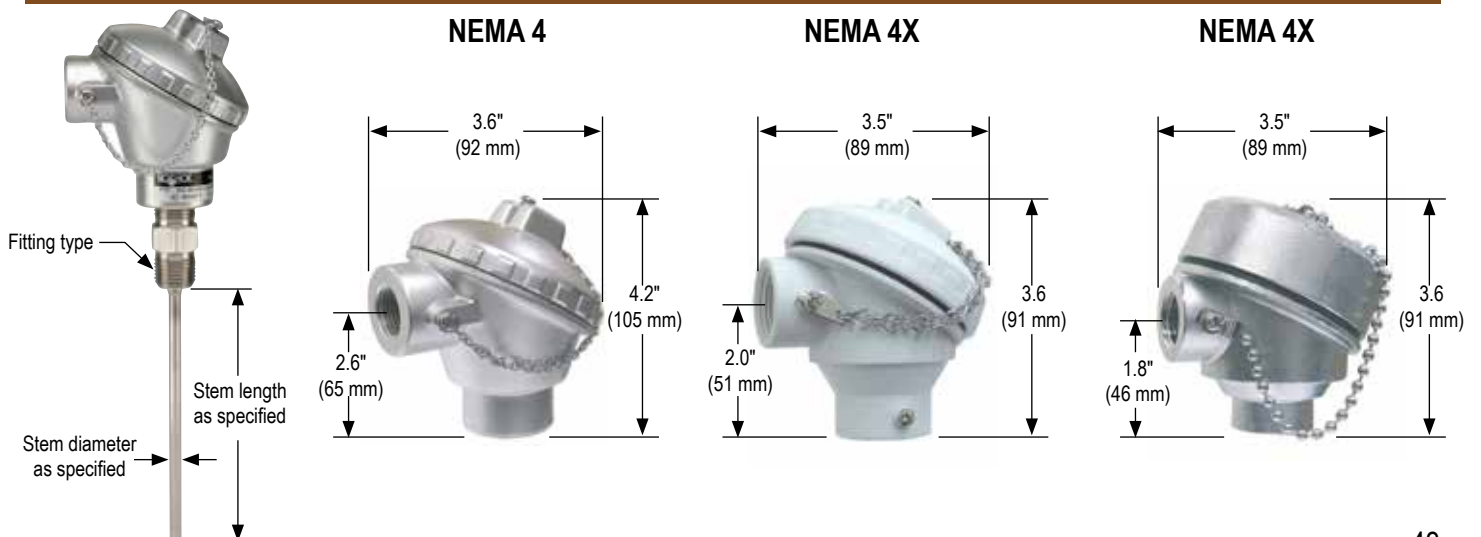

RTD Transmitter



920 SERIES

RTD TRANSMITTERS

- High accuracy ($\pm 0.1\%$)
- 2-wire loop-powered 4 mA to 20 mA output
- Linearized output to temperature
- Input RTD PT100 with 3-wire compensation
- Analog design, potentiometer adjustable
- Factory calibrated for fixed range
- Metal housing
- Fits standard heads
- Optional model is fully field re-programmable with module and PC-based software

ORDERING INFORMATION

SERIES	920		
TYPE	NRT Head-mounted		
INPUT	2 PT-100, 3-wire		
OUTPUTS	1 4 mA to 20 mA, 2-wire	2 0 Vdc to 5 Vdc, 3-wire	5 0 Vdc to 10 Vdc, 3-wire
CALIBRATED TEMPERATURE RANGE	Please specify low/high		
UNITS OF MEASURE	C Celsius	F Fahrenheit	
OPTIONS	0 None	PC* Computer Programmable	

Special configurations available on request, please consult your local NOSHOK Distributor or NOSHOK, Inc. for availability and delivery information.

*Requires program module and software, 4 mA to 20 mA only

@Vnom = 24 Vdc, T.ambient = 25 °C, Span nom. = 100 °C

EXAMPLE

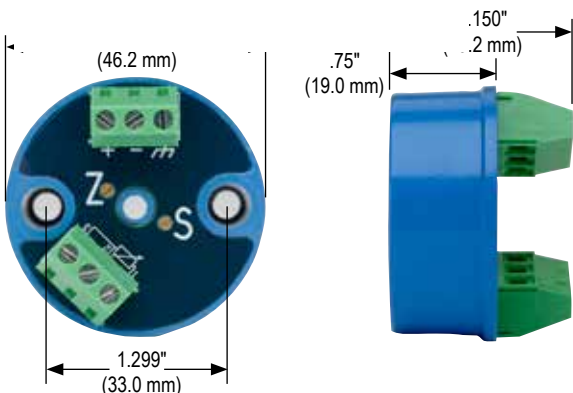
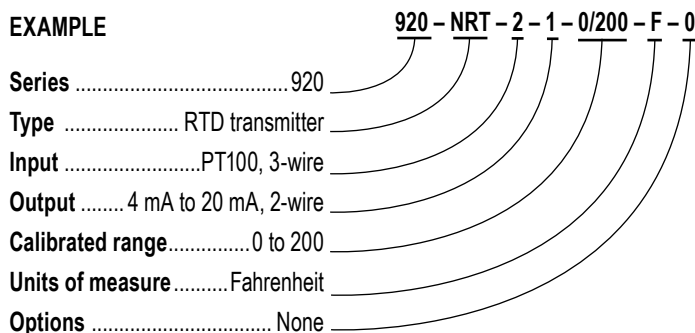

SPECIFICATIONS

Housing material	Die-cast zinc, enamel painted
Housing dimensions	1.82" dia. x 1.15" H
Input	PT100, 3-wire, $\alpha=0.00385$, DIN EN 60751
Output	4 mA to 20 mA loop powered or voltage, linear to temperature
Power requirement	12-32 Vdc, polarity protected
Supply effect	0.02%/V, 0.001%/V with computer programmable version
Zero drift	$\pm 0.01\%$ FS/ °C
Span drift	$\pm 0.01\%$ FS/ °C
Long term drift	$\leq 0.5\%$ FS/year
Excitation current RTD	0.8 mA
Sensor lead resistance RTD	500 Ω max.
Accuracy¹	0.1% FS (includes effects of linearity, hysteresis and repeatability)
Span/zero adjustment	20 turn potentiometer, $\pm 10\%$ for zero and span
Maximum loop resistance	$R_{max} = [(V_{supply} - 9 Vdc) / 20 mA]$
Open circuit detection	Overscale limit (27.0 mA) or underscale limit (2.2 mA)
Warm up	30 seconds
Temperature ranges	Ambient -40 °F to 176 °F (-40 °C to 80 °C) Storage -40 °F to 176 °F (-40 °C to 80 °C)

¹ Max. error on complete span. Error at calibration point ≤ 0.1 °C.

RTD Accessories

RTD CONNECTION HEADS

- Screw cover
- Meet NEMA requirements for indoor or outdoor use providing protection against dust, rain, splashing and hose-directed water
- Easy access, one-turn caps
- Accept standard and DIN terminal blocks and transmitters
- Provide greater volume for ease of field wiring



ORDERING INFORMATION				
SERIES	900			
TYPE	RCH RTD connection head			
MATERIALS	A1 Aluminum, general service	P1 PP (white), general service	S2 Stainless Steel, explosion proof *	
	A2 Aluminum, explosion proof*	S1 Stainless Steel, general service		
INSTRUMENT CONNECTION	04 1/2" NPT Female			
ELECTRICAL CONNECTIONS	04 1/2" NPT Female conduit	06 3/4" NPT Female conduit		

Special configurations available on request, please consult your local NOSHOK Distributor or NOSHOK, Inc. for availability and delivery information.

* Explosion proof Class I, Division I, Groups B, C and D; Class II, Division I, Groups E, F and H

EXAMPLE

900 - RCH - S1 - 04 - 06

Series900
 TypeRTD connection head
 MaterialStainless Steel, general service
 Process connection1/2" NPT Female
 Electrical connection3/4" NPT Female conduit

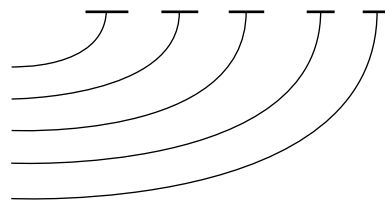

WARNING: This product can expose you to chemicals including Chromium (VI) and Nickel, which are known to the State of California to cause cancer and birth defects or other reproductive harm. For more information go to www.P65Warnings.ca.gov

RTD TERMINAL BLOCKS

- Provided with a steatite ceramic base, Brass terminal pieces, and Stainless Steel screws
- Not rated for high voltage use
- Can be used in temperature sensor or low voltage Class 2 circuits



ORDERING INFORMATION				
SERIES	900			
TYPE	RTB RTD terminal block			
MATERIALS	B Bakelite	C Ceramic		
	CONFIGURATIONS		2 2 position	4 4 position
			3 3 position	6 6 position

Special configurations available on request, please consult your local NOSHOK Distributor or NOSHOK, Inc. for availability and delivery information.

EXAMPLE

900 - RTB - C - 2

Series900
 TypeRTD terminal block
 MaterialCeramic
 Configuration2 position

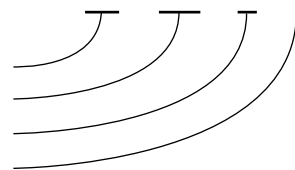

WARNING: This product can expose you to chemicals including Lead, which is known to the State of California to cause cancer and birth defects or other reproductive harm. For more information go to www.P65Warnings.ca.gov



WARNING: This product can expose you to chemicals including Chromium (VI) and Nickel, which are known to the State of California to cause cancer and birth defects or other reproductive harm. For more information go to www.P65Warnings.ca.gov

50/75/100 SERIES



- Allows a temperature instrument to be removed and replaced without shutting down and draining the process
- Reduces the possibility of damage to the temperature instrument
- Provides protection to the operator
- 1/2" NPSM instrument connection, 3/4" NPT process connection standard - 1/2" NPT, 1" NPT, flanged and sanitary options available
- 150 Class and 300 Class raised face flanged thermowells available
- The Female thread will accept the 1/2" NPT Male thread without galling or seizing
- Brass, 304 Stainless Steel, or 316 Stainless Steel standard material options - other options available
- Standard style is stepped; available in straight and tapered
- Different lagging lengths are available

APPLICATIONS

- Recommended wherever the process being measured is under pressure, corrosive, abrasive, or moving at a high velocity
- HVAC
- Petrochemical
- Oil and gas
- Process (flanged thermowells)

SPECIFICATIONS

Bore size	0.260" (6.35 mm)
Process connection	1/2" NPT, 3/4" NPT, 1" NPT
Instrument connection	1/2" NPSM
Materials	316 Stainless Steel, 304 Stainless Steel, Brass
Pressure rating	316 and 316 Stainless Steel: 7,000 psi @ 70 °F Brass: 5,000 psi @ 70 °F
Style	≤4": Straight shank >4": Stepped shank
Maximum shank diameter	0.750" (19.05 mm)



WARNING: This product can expose you to chemicals including Lead, which is known to the State of California to cause cancer and birth defects or other reproductive harm. For more information go to www.P65Warnings.ca.gov



WARNING: This product can expose you to chemicals including Chromium (VI) and Nickel, which are known to the State of California to cause cancer and birth defects or other reproductive harm. For more information go to www.P65Warnings.ca.gov

ORDERING INFORMATION						
PROCESS CONNECTIONS	50	1/2" NPT only	100	1" NPT or Flange Connection *	200	2" Flange Connection *
	75	3/4" NPT only	150	1-1/2" Flange Connection *		
STEM LENGTHS	025	2-1/2" **	120	12"	25mm	25 mm
	040	4" **	150	15"	50mm	50 mm
	060	6"	180	18"	100mm	100 mm
	090	9"	240	24"	150mm	150 mm
MATERIALS	Brass	Brass	304SS	304 Stainless Steel	316SS	316 Stainless Steel
		Other materials available on request				
OPTIONS	1/4	1/4" NPT Instrument Connection	PC	Plug and Chain	RF2	Raised Face 300 Class Flange
	3/8B	3/8" Diameter Bore	RF1	Raised Face 150 Class Flange	RTD	For use with 900/910 Series RTDs

Please consult your local NOSHOK Distributor or NOSHOK, Inc. for availability and delivery information.

* To order a Flange Connection, you must specify Option RF1 or RF2. Flange Connections available only in Stainless Steel.

** Flange Connection not available.

EXAMPLE

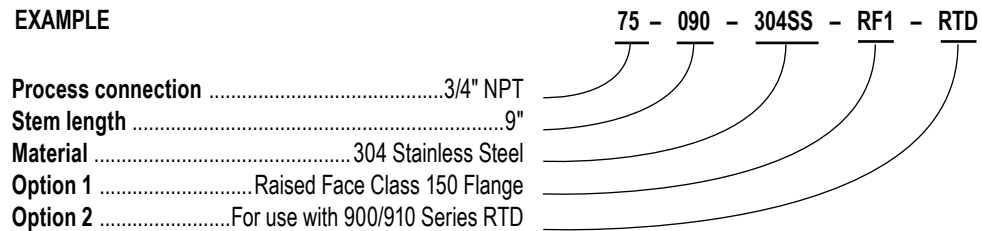

Straight Shank

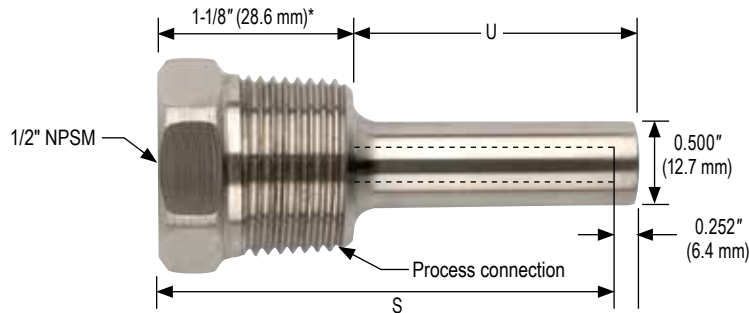

*1-3/4" (44.5 mm) for 040 Ordering Code

Stepped Shank

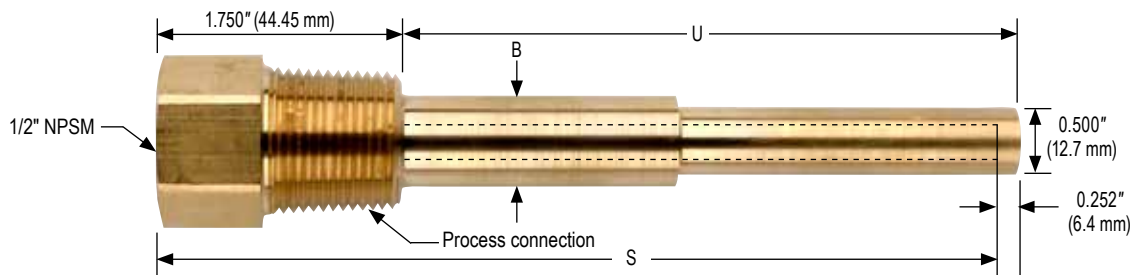

Bore Size	"B" Maximum Insertion Diameter
0.260" (6.35 mm)	3/4" (19.05 mm)

		Straight			Stepped					
Insertion "U"	mm	41.3	63.5	114.3	190.5	266.7	342.9	419.1	571.5	
	inch	1-5/8	2-1/2	4-1/2	7-1/2	10-1/2	13-1/2	16-1/2	22-1/2	
Bore Depth "S"	mm	63.5	101.6	152.4	228.6	304.8	381.0	457.2	609.6	
	inch	2-1/2	4	6	9	12	15	18	24	
Ordering Code		025	040	060	090	120	150	180	240	

Flange Connection Thermowell dimensions on next page.

RF1 150 Class & RF2 300 Class Raised Face Flanges

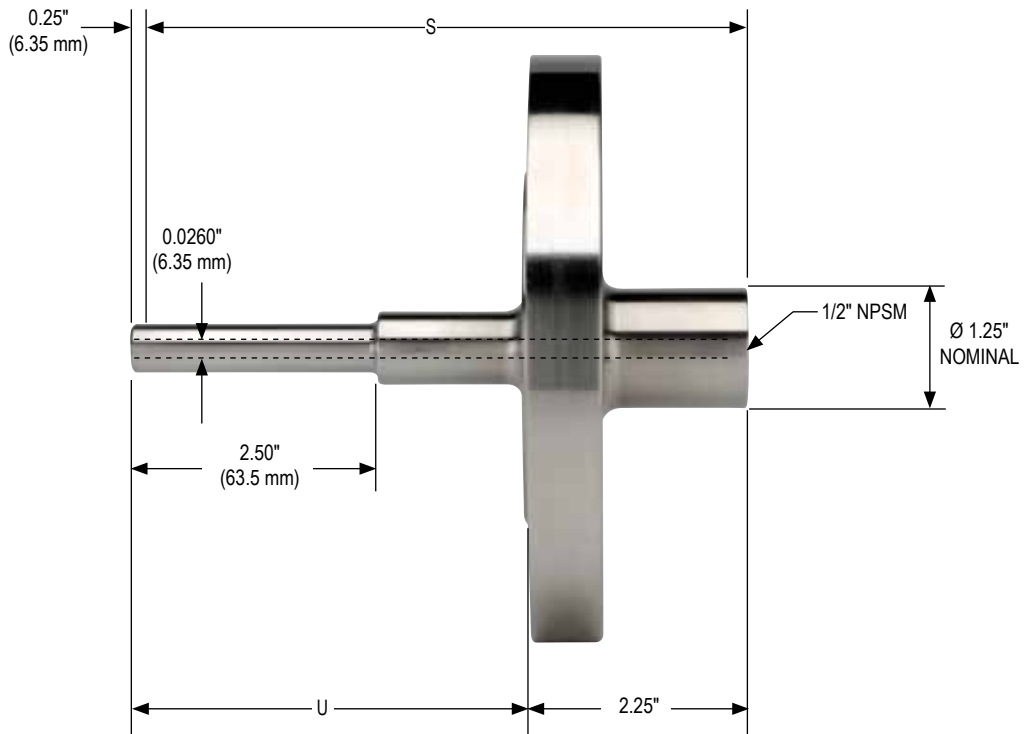

RF1 Class 150 Flange / RF2 Class 300 Flange							
Insertion "U"	mm	101.6	177.8	254.0	330.2	406.4	558.8
	inch	4	7	10	13	16	22
Bore Depth "S"	mm	152.4	228.6	304.8	381.0	457.2	609.6
	inch	6	9	12	15	18	24
Ordering Code		060	090	120	150	180	240

Note: NOSHOK Thermowells are provided with NPSM internal thread connections. This female connection may be used with NPT or NPSM mating threads. The NPSM thread provides a better mechanical connection without seizing or galling.

Standard Temperature Ranges / Figure Intervals

°F Ranges	Figure Interval	Div.	°C Ranges	Figure Interval	Div.
-100° to 150 °F	20°	2°	-70° to 70 °C	10°	1°
-80° to 120 °F	20°	2°	-60° to 50 °C	10°	1°
-40° to 120 °F	20°	2°	-40° to 50 °C	10°	1°
-20° to 120 °F	20°	2°	-30° to 50 °C	10°	1°
-40° to 160 °F	20°	2°	-40° to 70 °C	10°	1°
0° to 100 °F	10°	1°	-20° to 40 °C	5°	1/2°
25° to 125 °F	10°	1°	-5° to 50 °C	5°	1/2°
30° to 130 °F	10°	1°	0° to 55 °C	5°	1/2°
0° to 140 °F	10°	1°	-20° to 60 °C	5°	1/2°
0° to 200 °F	20°	2°	-15° to 90 °C	10°	1°
0° to 250 °F	20°	2°	-20° to 120 °C	10°	1°
20° to 240 °F	20°	2°	-5° to 115 °C	10°	1°
50° to 300 °F	20°	2°	10° to 150 °C	10°	1°
50° to 400 °F	50°	5°	10° to 200 °C	20°	2°
50° to 500 °F	50°	5°	10° to 260 °C	20°	2°
50° to 550 °F	50°	5°	10° to 290 °C	20°	2°
0° to 600 °F	100°	10°	-20° to 315 °C	50°	5°
150° to 750 °F	100°	10°	65° to 400 °C	50°	5°
100° to 800 °F	100°	10°	40° to 425 °C	50°	5°
200° to 1,000 °F	100°	10°	100° to 540 °C	50°	5°

Thermowells: Pressure Rating vs. Temperature

Thermowell Material	Temperature in Degrees Fahrenheit						
	70 °F	200 °F	400 °F	600 °F	800 °F	1,000 °F	1,200 °F
	Pressure Rating (Pounds Per Square Inch)						
Brass	5,000	4,200	1,000	-	-	-	-
Welded Stainless Steel	982	820	675	604	550	510	299
304 Stainless Steel	7,000	6,200	5,600	5,400	5,200	4,500	1,650
316 Stainless Steel	7,000	7,000	6,400	6,200	6,100	5,100	2,500

Thermowells: Maximum Fluid Velocity vs. Insertion Length

Thermowell Material	Fluid Type	Insertion Length (Inches)		
		2"	4"	8"
		Maximum Fluid Velocity (Feet per Second)		
Brass	Air/Steam	207	75.5	27.3
	Water	59.3	32.2	19.7
Welded Stainless Steel	Air/Steam	169	61	20
	Water	88	20	10
304 Stainless Steel	Air/Steam	300	109	39.5
316 Stainless Steel	Water	148	82.2	-

Note: The values shown in this table are based on operating temperatures of 350 °F for Brass and 1,000 °F for Stainless Steel. Slightly higher velocities are possible at lower temperatures.

RTD Temperature vs. Resistance Table (Alpha +0.00385)

°C	°F	Ohms	°C	°F	Ohms	°C	°F	Ohms	°C	°F	Ohms	°C	°F	Ohms
-75	-103	101.95	-27	-16.6	89.4	21	69.8	108.18	69	156.2	126.7	117	242.6	144.94
-74	-101.2	70.73	-26	-14.8	89.8	22	71.6	108.57	70	158	127.08	118	244.4	145.32
-73	-99.4	71.13	-25	-13	90.19	23	73.4	108.96	71	159.8	127.46	119	246.2	145.69
-72	-97.6	71.53	-24	-11.2	90.59	24	75.2	109.35	72	161.6	127.85	120	248	146.07
-71	-95.8	71.93	-23	-9.4	90.98	25	77	109.73	73	163.4	128.23	121	249.8	146.45
-70	-94	72.33	-22	-7.6	91.37	26	78.8	110.12	74	165.2	128.61	122	251.6	146.82
-69	-92.2	72.73	-21	-5.8	91.77	27	80.6	110.51	75	167	128.99	123	253.4	147.2
-68	-90.4	73.13	-20	-4	92.16	28	82.4	110.9	76	168.8	129.38	124	255.2	147.58
-67	-88.6	73.53	-19	-2.2	92.55	29	84.2	111.28	77	170.6	129.76	125	257	147.95
-66	-86.8	73.93	-18	-0.4	92.95	30	86	111.67	78	172.4	130.14	126	258.8	148.33
-65	-85	74.33	-17	1.4	93.34	31	87.8	112.06	79	174.2	130.52	127	260.6	148.71
-64	-83.2	74.73	-16	3.2	93.73	32	89.6	112.45	80	176	130.9	128	262.4	149.08
-63	-81.4	75.13	-15	5	94.12	33	91.4	112.83	81	177.8	131.28	129	264.2	149.46
-62	-79.6	75.53	-14	6.8	94.52	34	93.2	113.22	82	179.6	131.67	130	266	149.83
-61	-77.8	75.93	-13	8.6	94.91	35	95	113.61	83	181.4	132.05	131	267.8	150.21
-60	-76	76.33	-12	10.4	95.3	36	96.8	113.99	84	183.2	132.43	132	269.6	150.58
-59	-74.2	76.73	-11	12.2	95.69	37	98.6	114.38	85	185	132.81	133	271.4	150.96
-58	-72.4	77.13	-10	14	96.09	38	100.4	114.77	86	186.8	133.19	134	273.2	151.34
-57	-70.6	77.52	-9	15.8	96.48	39	102.2	115.15	87	188.6	133.57	135	275	151.71
-56	-68.8	77.92	-8	17.6	96.87	40	104	115.54	88	190.4	133.95	136	276.8	152.09
-55	-67	78.32	-7	19.4	97.26	41	105.8	115.93	89	192.2	134.33	137	278.6	152.46
-54	-65.2	78.72	-6	21.2	97.65	42	107.6	116.31	90	194	134.71	138	280.4	152.84
-53	-63.4	79.11	-5	23	98.04	43	109.4	116.7	91	195.8	135.09	139	282.2	153.21
-52	-61.6	79.51	-4	24.8	98.44	44	111.2	117.08	92	197.6	135.47	140	284	153.58
-51	-59.8	79.91	-3	26.6	98.83	45	113	117.47	93	199.4	135.85	141	285.8	153.95
-50	-58	80.31	-2	28.4	99.22	46	114.8	117.85	94	201.2	136.23	142	287.6	154.32
-49	-56.2	80.7	-1	30.2	99.61	47	116.6	118.24	95	203	136.61	143	289.4	154.71
-48	-54.4	81.1	0	32	100	48	118.4	118.62	96	204.8	136.99	144	291.2	155.08
-47	-52.6	81.5	1	33.8	100.39	49	120.2	119.01	97	206.6	137.37	145	293	155.46
-46	-50.8	81.89	2	35.6	100.78	50	122	119.4	98	208.4	137.75	146	294.8	155.83
-45	-49	82.29	3	37.4	101.17	51	123.8	119.78	99	210.2	138.13	147	296.6	156.21
-44	-47.2	82.69	4	39.2	101.56	52	125.6	120.16	100	212	138.51	148	298.4	156.58
-43	-45.4	83.08	5	41	101.95	53	127.4	120.55	101	213.8	138.89	149	300.2	156.96
-42	-43.6	83.48	6	42.8	102.34	54	129.2	120.93	102	215.6	139.27	150	302	157.33
-41	-41.8	83.88	7	44.6	102.73	55	131	121.32	103	217.4	139.65	151	303.8	157.71
-40	-40	84.27	8	46.4	103.12	56	132.8	121.7	104	219.2	140.03	152	305.6	158.08
-39	-38.2	84.67	9	48.2	103.51	57	134.6	122.09	105	221	140.39	153	307.4	158.45
-38	-36.4	85.06	10	50	103.9	58	136.4	122.47	106	222.8	140.77	154	309.2	158.83
-37	-34.6	85.46	11	51.8	104.29	59	138.2	122.86	107	224.6	141.15	155	311	159.2
-36	-32.8	85.85	12	53.6	104.68	60	140	123.24	108	226.4	141.53	156	312.8	159.56
-35	-31	86.25	13	55.4	105.07	61	141.8	123.62	109	228.2	141.91	157	314.6	159.94
-34	-29.2	86.64	14	57.2	105.46	62	143.6	124.01	110	230	142.29	158	316.4	160.31
-33	-27.4	87.04	15	59	105.85	63	145.4	124.39	111	231.8	142.66	159	318.2	160.68
-32	-25.6	87.43	16	60.8	106.24	64	147.2	124.77	112	233.6	143.04	160	320	161.05
-31	-23.8	87.83	17	62.6	106.63	65	149	125.17	113	235.4	143.42	161	321.8	161.43
-30	-22	88.22	18	64.4	107.02	66	150.8	125.55	114	237.2	143.8	162	323.6	161.8
-29	-20.2	88.62	19	66.2	107.4	67	152.6	125.93	115	239	144.18	163	325.4	162.17
-28	-18.4	89.01	20	68	107.79	68	154.4	126.32	116	240.8	144.56	164	327.2	162.54

RTD Temperature vs. Resistance Table (Alpha +0.00385)

°C	°F	Ohms	°C	°F	Ohms	°C	°F	Ohms	°C	°F	Ohms	°C	°F	Ohms
165	329	162.91	213	415.4	180.63	261	501.8	198.07	309	588.2	215.26	357	674.6	232.16
166	330.8	163.28	214	417.2	180.99	262	503.6	198.43	310	590	215.61	358	676.4	232.51
167	332.6	163.66	215	419	181.36	263	505.4	198.79	311	591.8	215.97	359	678.2	232.86
168	334.4	164.03	216	420.8	181.73	264	507.2	199.15	312	593.6	216.32	360	680	233.21
169	336.2	164.4	217	422.6	182.09	265	509	199.51	313	595.4	216.68	361	681.8	233.56
170	338	164.77	218	424.4	182.46	266	510.8	199.87	314	597.2	217.03	362	683.6	233.91
171	339.8	165.14	219	426.2	182.82	267	512.6	200.23	315	599	217.39	363	685.4	234.26
172	341.6	165.51	220	428	183.19	268	514.4	200.59	316	600.8	217.73	364	687.2	234.6
173	343.4	165.88	221	429.8	183.55	269	516.2	200.95	317	602.6	218.08	365	689	234.95
174	345.2	166.25	222	431.6	183.92	270	518	201.31	318	604.4	218.44	366	690.8	235.3
175	347	166.62	223	433.4	184.28	271	519.8	201.67	319	606.2	218.79	367	692.6	235.65
176	348.8	167	224	435.2	184.65	272	521.6	202.03	320	608	219.15	368	694.4	236
177	350.6	167.37	225	437	185.01	273	523.4	202.38	321	609.8	219.5	369	696.2	236.35
178	352.4	167.74	226	438.8	185.38	274	525.2	202.74	322	611.6	219.85	370	698	236.7
179	354.2	168.11	227	440.6	185.74	275	527	203.1	323	613.4	220.21	371	699.8	237.05
180	356	168.48	228	442.4	186.11	276	528.8	203.46	324	615.2	220.56	372	701.6	237.4
181	357.8	168.85	229	444.2	186.47	277	530.6	203.82	325	617	220.91	373	703.4	237.75
182	359.6	169.22	230	446	186.84	278	532.4	204.18	326	618.8	221.27	374	705.2	238.09
183	361.4	169.59	231	447.8	187.2	279	534.2	204.54	327	620.6	221.62	375	707	238.44
184	363.2	169.96	232	449.6	187.56	280	536	204.9	328	622.4	221.97	376	708.8	238.79
185	365	170.33	233	451.4	187.93	281	537.8	205.25	329	624.2	222.32	377	710.6	239.14
186	366.8	170.69	234	453.2	188.29	282	539.6	205.61	330	626	222.68	378	712.4	239.48
187	368.6	171.06	235	455	188.65	283	541.4	205.97	331	627.8	223.03	379	714.2	239.83
188	370.4	171.43	236	456.8	189.02	284	543.2	206.33	332	629.6	223.38	380	716	240.18
189	372.2	171.8	237	458.6	189.38	285	545	206.7	333	631.4	223.73	381	717.8	240.52
190	374	172.17	238	460.4	189.74	286	546.8	207.05	334	633.2	224.09	382	719.6	240.87
191	375.8	172.54	239	462.2	190.11	287	548.6	207.41	335	635	224.45	383	721.4	241.22
192	377.6	172.91	240	464	190.47	288	550.4	207.77	336	636.8	224.8	384	723.2	241.56
193	379.4	173.27	241	465.8	190.83	289	552.2	208.13	337	638.6	225.15	385	725	241.91
194	381.2	173.64	242	467.6	191.2	290	554	208.48	338	640.4	225.5	386	726.8	242.25
195	383	174.01	243	469.4	191.56	291	555.8	208.84	339	642.2	225.85	387	728.6	242.6
196	384.8	174.39	244	471.2	191.92	292	557.6	209.2	340	644	226.21	388	730.4	242.95
197	386.6	174.75	245	473	192.28	293	559.4	209.55	341	645.8	226.56	389	732.2	243.29
198	388.4	175.12	246	474.8	192.66	294	561.2	209.91	342	647.6	226.91	390	734	243.64
199	390.2	175.49	247	476.6	193.02	295	563	210.27	343	649.4	227.26	391	735.8	243.98
200	392	175.86	248	478.4	193.38	296	564.8	210.62	344	651.2	227.61	392	737.6	244.33
201	393.8	176.23	249	480.2	193.74	297	566.6	210.98	345	653	227.96	393	739.4	244.67
202	395.6	176.59	250	482	194.1	298	568.4	211.34	346	654.8	228.31	394	741.2	245.02
203	397.4	176.96	251	483.8	194.47	299	570.2	211.69	347	656.6	228.66	395	743	245.36
204	399.2	177.33	252	485.6	194.83	300	572	212.05	348	658.4	229.01	396	744.8	245.71
205	401	177.7	253	487.4	195.19	301	573.8	212.4	349	660.2	229.36	397	746.6	246.05
206	402.8	178.06	254	489.2	195.55	302	575.6	212.76	350	662	229.72	398	748.4	246.4
207	404.6	178.43	255	491	195.9	303	577.4	213.12	351	663.8	230.07	399	750.2	246.74
208	406.4	178.8	256	492.8	196.26	304	579.2	213.47	352	665.6	230.42	400	752	247.09
209	408.2	179.16	257	494.6	196.62	305	581	213.83	353	667.4	230.77			
210	410	179.53	258	496.4	196.98	306	582.8	214.19	354	669.2	231.12			
211	411.8	179.9	259	498.2	197.35	307	584.6	214.55	355	671	231.47			
212	413.6	180.26	260	500	197.71	308	586.4	214.9	356	672.8	231.81			

Temperature Conversions

	From Fahrenheit	To Fahrenheit
Celsius	$[^{\circ}\text{C}] = ([^{\circ}\text{F}] - 32) \times 5/9$	$[^{\circ}\text{F}] = [^{\circ}\text{C}] \times 9/5 + 32$
Kelvin	$[\text{K}] = ([^{\circ}\text{F}] + 459.67) \times 5/9$	$[^{\circ}\text{F}] = [\text{K}] \times 9/5 - 459.67$
Rankine	$[^{\circ}\text{R}] = [^{\circ}\text{F}] + 459.67$	$[^{\circ}\text{F}] = [^{\circ}\text{R}] - 459.67$
Delisle	$[^{\circ}\text{De}] = (212 - [^{\circ}\text{F}]) \times 5/6$	$[^{\circ}\text{F}] = 212 - [^{\circ}\text{De}] \times 6/5$
Newton	$[^{\circ}\text{N}] = ([^{\circ}\text{F}] - 32) \times 11/60$	$[^{\circ}\text{F}] = [^{\circ}\text{N}] \times 60/11 + 32$
Réaumur	$[^{\circ}\text{Ré}] = ([^{\circ}\text{F}] - 32) \times 4/9$	$[^{\circ}\text{F}] = [^{\circ}\text{Ré}] \times 9/4 + 32$
Rømer	$[^{\circ}\text{Rø}] = ([^{\circ}\text{F}] - 32) \times 7/24 + 7.5$	$[^{\circ}\text{F}] = ([^{\circ}\text{Rø}] - 7.5) \times 24/7 + 32$

	From Celsius (Centigrade)	To Celsius (Centigrade)
Fahrenheit	$[^{\circ}\text{F}] = [^{\circ}\text{C}] \times 9/5 + 32$	$[^{\circ}\text{C}] = ([^{\circ}\text{F}] - 32) \times 5/9$
Kelvin	$[\text{K}] = [^{\circ}\text{C}] + 273.15$	$[^{\circ}\text{C}] = [\text{K}] - 273.15$
Rankine	$[^{\circ}\text{R}] = ([^{\circ}\text{C}] + 273.15) \times 9/5$	$[^{\circ}\text{C}] = ([^{\circ}\text{R}] - 491.67) \times 5/9$
Delisle	$[^{\circ}\text{De}] = (100 - [^{\circ}\text{C}]) \times 3/2$	$[^{\circ}\text{C}] = 100 - [^{\circ}\text{De}] \times 2/3$
Newton	$[^{\circ}\text{N}] = [^{\circ}\text{C}] \times 33/100$	$[^{\circ}\text{C}] = [^{\circ}\text{N}] \times 100/33$
Réaumur	$[^{\circ}\text{Ré}] = [^{\circ}\text{C}] \times 4/5$	$[^{\circ}\text{C}] = [^{\circ}\text{Ré}] \times 5/4$
Rømer	$[^{\circ}\text{Rø}] = [^{\circ}\text{C}] \times 21/40 + 7.5$	$[^{\circ}\text{C}] = ([^{\circ}\text{Rø}] - 7.5) \times 40/21$

	From Kelvin	To Kelvin
Celsius	$[^{\circ}\text{C}] = [\text{K}] - 273.15$	$[\text{K}] = [^{\circ}\text{C}] + 273.15$
Fahrenheit	$[^{\circ}\text{F}] = [\text{K}] \times 9/5 - 459.67$	$[\text{K}] = ([^{\circ}\text{F}] + 459.67) \times 5/9$
Rankine	$[^{\circ}\text{R}] = [\text{K}] \times 9/5$	$[\text{K}] = [^{\circ}\text{R}] \times 5/9$
Delisle	$[^{\circ}\text{De}] = (373.15 - [\text{K}]) \times 3/2$	$[\text{K}] = 373.15 - [^{\circ}\text{De}] \times 2/3$
Newton	$[^{\circ}\text{N}] = ([\text{K}] - 273.15) \times 33/100$	$[\text{K}] = [^{\circ}\text{N}] \times 100/33 + 273.15$
Réaumur	$[^{\circ}\text{Ré}] = ([\text{K}] - 273.15) \times 4/5$	$[\text{K}] = [^{\circ}\text{Ré}] \times 5/4 + 273.15$
Rømer	$[^{\circ}\text{Rø}] = ([\text{K}] - 273.15) \times 21/40 + 7.5$	$[\text{K}] = ([^{\circ}\text{Rø}] - 7.5) \times 40/21 + 273.15$

Wiring Diagrams

2-Wire

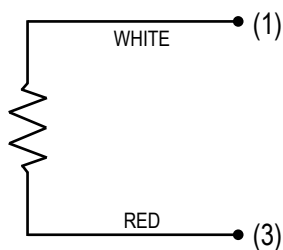

3-Wire

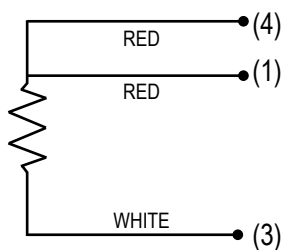

4-Wire

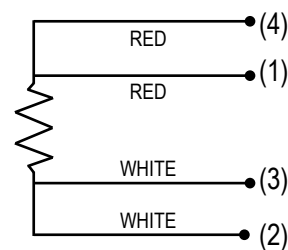

Dual 2-Wire

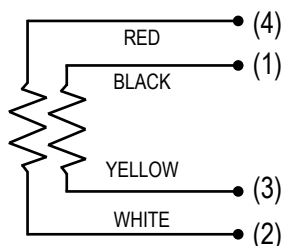

Dual 3-Wire

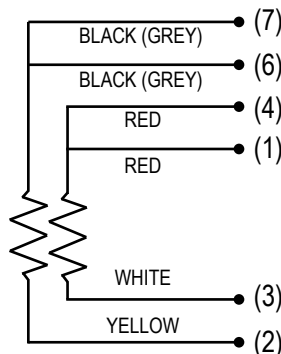

Dual 4-Wire

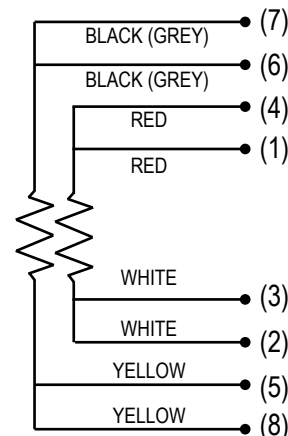

Thermometer Tolerance Classes per EN 60751

Tolerance Classes	Resistance Tolerance at 0 °C	Tolerance as a Function of Absolute Value of Temperature in °C
Class AA	$\pm 0.04\%$ (± 0.1 °C)	$\pm [0.1 + (0.0017 * t)]$
Class A	$\pm 0.06\%$ (± 0.15 °C)	$\pm [0.15 + (0.002 * t)]$
Class B	$\pm 0.12\%$ (± 0.3 °C)	$\pm [0.3 + (0.005 * t)]$
Class C	$\pm 0.23\%$ (± 0.6 °C)	$\pm [0.6 + (0.01 * t)]$

RTD Standards

Organization	Standard	ALPHA: Average Temperature Coefficient of Resistance (0 °C) ⁻¹	Nominal Resistance at 0 °C
British Standard	BS 1904 : 1984	0.003850	100
Deutsch Industrial Norm	DIN 43760 :1980	0.003850	100
International Electrotechnical Commission	IEC 751 : 1995 (Amend. 2)	0.003850	100
Scientific Apparatus Manufacturers of America	SAMA RC-4-1966	0.003923	98.129
Japanese Standard	JIS C1604-1981	0.003916	100
American Society for Testing & Materials	ASTM E1137	0.003850	100

TO DOWNLOAD OR ORDER CATALOGS,
VISIT WWW.NOSHOK.COM

Quality Policy

NOSHOK
is committed to providing
a high degree of value and continually
improving processes to improve customer
satisfaction by focusing on customer
requirements for the design, manufacture and
distribution of pressure, temperature, and
force measurement instruments along with
needle and manifold valves including
custom manifold systems for
industrial applications.

All from world class technology.

Combined with real-world stamina.

The highest value with the industry's best warranty.

And all from a company with a 50+ year record of customer satisfaction.

All from your Single Source Instrumentation Company.



Corporate Headquarters

1010 West Bagley Road
Berea, Ohio 44017
Ph: 440.243.0888
Fax: 440.243.3472
E-mail: noshok@noshok.com
Web: www.noshok.com

